

HSW-ES Sliding Glass Walls

Easy Safe

Installation instructions

940001 – 05-2019

| EN |

dormakaba 

Table of contents

1	Technical specifications	3		
1.1	Overview	3		
1.1.1	General information	3		
1.1.2	Intended use	3		
1.1.3	Glass requirements/fittings/mounting	3		
1.1.4	Requirements for glass panel	3		
1.1.5	Safety instructions	3		
1.1.6	Symbols used - Safety/Installation	3		
1.1.7	Maintenance, care, repair	3		
1.1.8	Disposal	3		
1.2	Specification - technical data	4		
1.3	Tempered laminate glass (TLG) and adhesive specifications	4		
1.4	Tools required	4		
1.5	Installation options/Overall top of door components	5		
1.6	Installation options/Bottom of door components	6		
1.7	Installation options/Bottom of door components (continued)	7		
2	Installation instructions - Prepare track	8		
2.1	Determine the track arrangement	8		
2.2	Install single-action pivoting end panel retaining clip	9		
2.3	Install door track stop in stacking area	10		
2.4	Installing the track	11		
2.5	Installing upper pivot block	12		
2.6	Install rollers in track	13		
2.7	Install revision piece	14		
2.8	Prepare the roller pattern in the track	15		
3	Installation instructions - DA & SA pivoting end panel	16		
3.1	Preparing the DA & SA pivoting end panel (with monolithic glass only)	16		
3.2	Preparing the DA & SA pivoting end panel (with tempered laminated glass only)	17		
3.3	Preparing the upper pivot block	18		
3.4	Install floor pivot or BTS80 closer	19		
3.5	Install pivot into end panel carrier profile	20		
3.6	Install top cover gasket	21		
3.7	Installing top covers	21		
3.8	Install DA & SA pivoting end panel into track	22		
3.9	Secure end panel in track	23		
4	Installation instructions - Sliding panel	24		
4.1	Preparing the sliding panel (with monolithic glass only)	24		
4.2	Preparing the sliding panel (with tempered laminated glass only)	25		
4.3	Install sliding panel onto rollers and adjust door height	26		
4.4	Install gasket and top cover	27		
5	Installation instructions - Double-action sliding panel with ITS96	28		
5.1	Preparing the DA sliding panel (with monolithic glass)	28		
5.2	Preparing the DA sliding panel (with tempered laminated glass only)	29		
5.3	Installing three piece lock	30		
5.4	Prep for installing two piece lock (when required)	31		
5.5	Install top cover and carrier profile gaskets	31		
5.6	Installing three piece lock (continued)	32		
5.7	Install two piece lock (continued)	33		
5.8	Installing DA sliding panels onto rollers and adjust door height	34		
5.9	Secure three piece lock to track	35		
5.10	Secure two piece lock to track	36		
5.11	ITS96 closer adjustment	37		
5.12	ITS96 hold open (optional) and spring force adjustment	38		
6	Installation instructions - Fixed panel door	39		
6.1	Preparing the fixed panel door (with monolithic glass only)	39		
6.2	Preparing the fixed panel door (with tempered laminated glass only)	40		
6.3	Installing the fixed panel holders	41		
6.4	Installing the saddle and fixed panel door	42		
6.5	Adjusting and securing fixed panel door	43		
6.6	Install gasket and top cover	44		
7	Installation instructions - Alignment, covers, end caps, miscellaneous	45		
7.1	Aligning panels into stacking area	45		
7.2	Aligning panels side by side in straight run	46		
7.3	Secure carrier profile file connecting inserts and end caps	47		
7.4	Drilling for ES locking bolt strike	48		
7.5	Secure bottom rail covers and rail lock preparation	49		
7.6	Installing the brush	50		
7.7	Selecting the proper end cap	51		
7.8	Secure the end caps	52		

1 Technical specifications

1.1 Overview

These instructions are for installation of HSW-ES Sliding Wall Systems for the following mounting and style versions:

1. Ceiling mount

1.1.1 General information

- dormakaba requires use of tempered laminated or tempered monolithic glass.
- dormakaba glass hardware is not suitable for harsh environment; for example, applications where chemicals (e.g. chlorine) are used such as indoor swimming pools, saunas, or salt-water pools.
- Never move sliding panels faster than walking speed and always stop the door manually before it reaches end position.
- Do not slide doors with excessive force. Ensure proper installation of limiting stop to prevent door from opening too far.
- Do not swing doors with excessive force. Recommended install of limiting stop to prevent door from opening too far.

1.1.2 Intended use

- For sliding doors in wet or dry indoor areas only.
- For manual slow opening and closing only.

1.1.3 Glass requirements/fittings/mounting

- The structural support must be able to bear permanent loads. Track must be level to 1/8" [3] over 10' [3048] non-cumulative. Maximum deflection ±1/8" [±3] over 10' [3048] non-cumulative. Finished floor must be level to within ±1/8" [±3] over 10' [3048] non-cumulative.
- Fasteners must be sufficiently dimensioned for the substructure/wall and weight of the door.
- When adjusting glass components, always stick to the required clearance for the respective hardware. Adjust clearance so glass does not come in contact with any hard surfaces such as glass, metal or concrete.
- Do not use excessive force when installing the glass (avoid over tightening screws.)

1.1.4 Requirements for glass panel

- dormakaba requires use of fully tempered glass, which complies with ASTM C 1036 and ASTM C 1048. Secondary heat soaking processes are recommended but not required. This applies to both tempered monolithic and tempered laminated glass.
- Clamping area must be flat and uncoated (no self-cleaning coating!)
- Never use glass with conchoidal fractures and/or damaged edges.

1.1.5 Safety instructions

- Installation requires two people.
- Always wear protective clothing.

- Only properly qualified and specially trained staff are authorized to mount dormakaba glass hardware.
- Due to crushing hazards and possible injury caused by breakage of glass during mounting, corresponding protective clothing (especially gloves and protective goggles) is required.
- Never clamp metal fitting hardware directly to glass surface.

1.1.6 Symbols used - Safety/Installation



CAUTION

Mounting components must meet the requirements of substructure/wall and door weight. Please read the technical information for fittings.



WARNING

Risk of breaking glass. When installing the door, support the door panel with a block of wood or similar object.



WARNING

Risk of pinching. When sliding the panels ensure hands and body parts are free from between the closing edges.



TIPS AND RECOMMENDATIONS



CLOSING EDGE OF DOOR

1.1.7 Maintenance, care, repair

- Immediately replace damaged parts.
- Always use original dormakaba parts.
- Clean clamping area with alcohol-based standard commercial cleaning agent before mounting the glass hardware.
- Use a damp cloth for occasional cleaning.
- Always use silicone - and oil-free cleaners (e.g. acetone).
- Check glass hardware at regular intervals for proper positioning, smooth operation and correct adjustment.
- High traffic door systems require inspection by properly trained or qualified staff (specialized companies or installation firms.)

1.1.8 Disposal

Disposal in accordance with local, state and national regulations.

1.2 Specification - technical data

		Pivoting end panel	Sliding panel	Double action sliding panel	Fixed panel
Ceiling mount	Maximum door leaf weight lbs [kg] *	≤ 330 lbs [≤ 150]	≤ 330 lbs [≤ 150]	≤ 264 lbs [≤ 120]	≤ 330 lbs [≤ 150]

* Including weight of auxiliary hardware.

1.3 Tempered laminate glass (TLG) and adhesive specifications

Required parts for laminate glass (not included)	Part Number	Quantity	Usage recommendation
3M™ Scotch-Weld™ Urethane Adhesive, DP 605 NS	934.800	1 tube	1 tube per 4 roller carriers
3M™ Scotch-Weld™ EPX™ Plus II Applicator with 1:1 Plunger ¹	934.801	1 applicator	1:1 plunger with 934.800 adhesive
3M™ Scotch-Weld™ EPX™ Plus II Mixing Square Nozzle, 5.3mm ²	934.805	Pk of 4	4 nozzles per 1 tube of adhesive
Handling time frame	Function	Time	
	Working life (<i>time between application and clamping of carrier</i>)	5 minutes @ 75°F	
	Handling strength	20 minutes @ 73°F or more	
	Full cure time (<i>normal door usage not recommended until full cure time has been met</i>)	48 hours @ 73°F or more	

NOTE: Door glass should not be installed until the full cure time has been reached (see chart above).

- 1.1 Clean clamping area with alcohol-based standard commercial cleaning agent before mounting the glass hardware.

Important safety-related information for the mounting and use of dormakaba glass hardware.

- 1.2 Never clamp metal fitting hardware directly to glass surface.
- 1.3 Never use clamping products on surfaces with self-cleaning coatings.

1.4 Tools required

Tools required	
Rubber mallet	Pliers
Plumb bob	Wrench: 8mm, 15mm, 17mm
Drill	Hex key: 3mm, 5mm, 6mm
∅ 25 mm hole saw	Torque wrench
∅ 40 mm hole saw	Cross head screw driver
∅ 8 mm drill bit	Flat head screw driver
Tape measure	Setting blocks
Laser level	

1 Scotch-Weld™ EPX™ Plus II Applicator with 1:1 Plunger is a trademark of 3M.

2 Scotch-Weld™ EPX™ Plus II Mixing Square Nozzle is a trademark of 3M.

1.5 Installation options/Overall top of door components

Fig 1

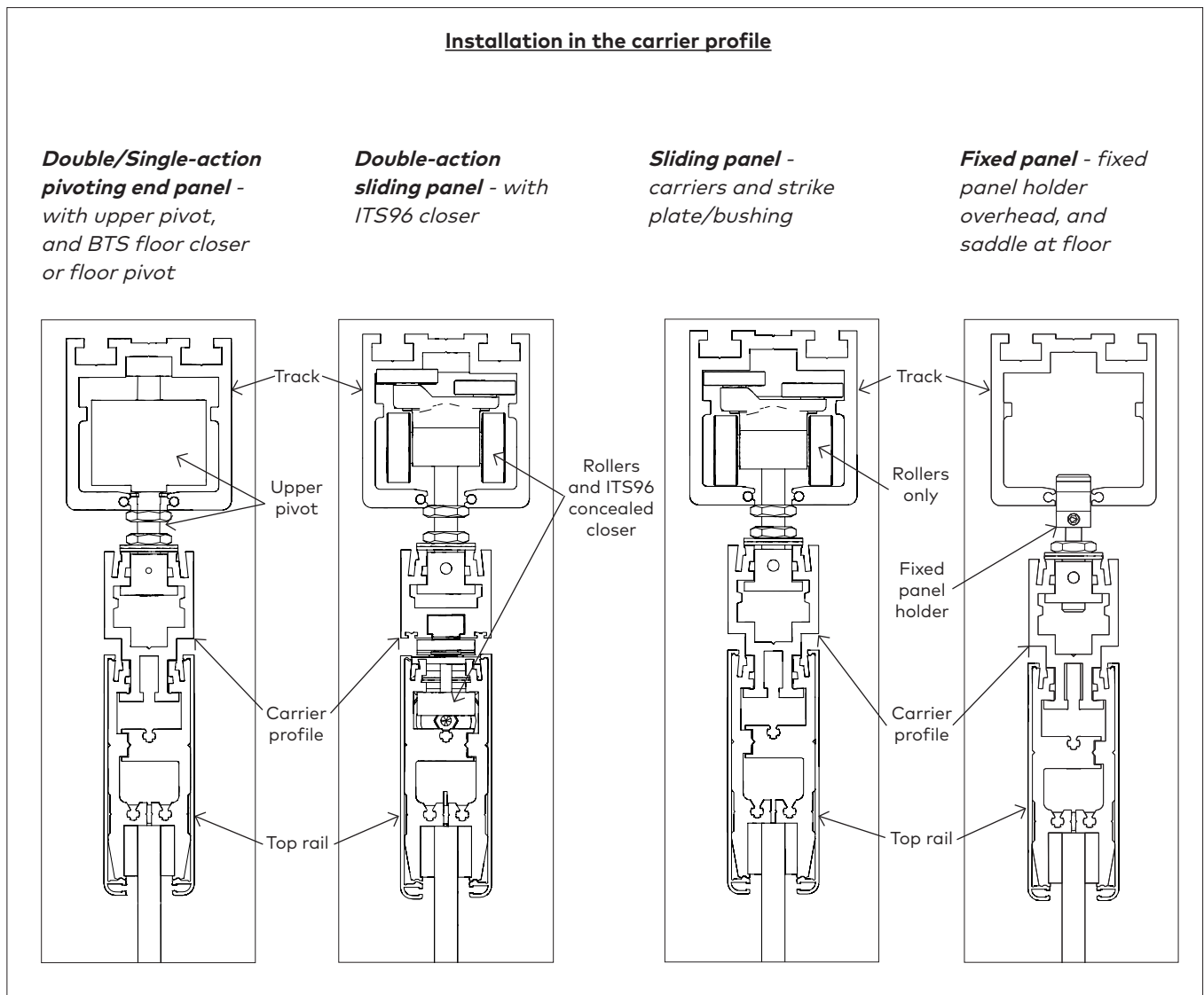

1.6 Installation options/Bottom of door components

Fig 2

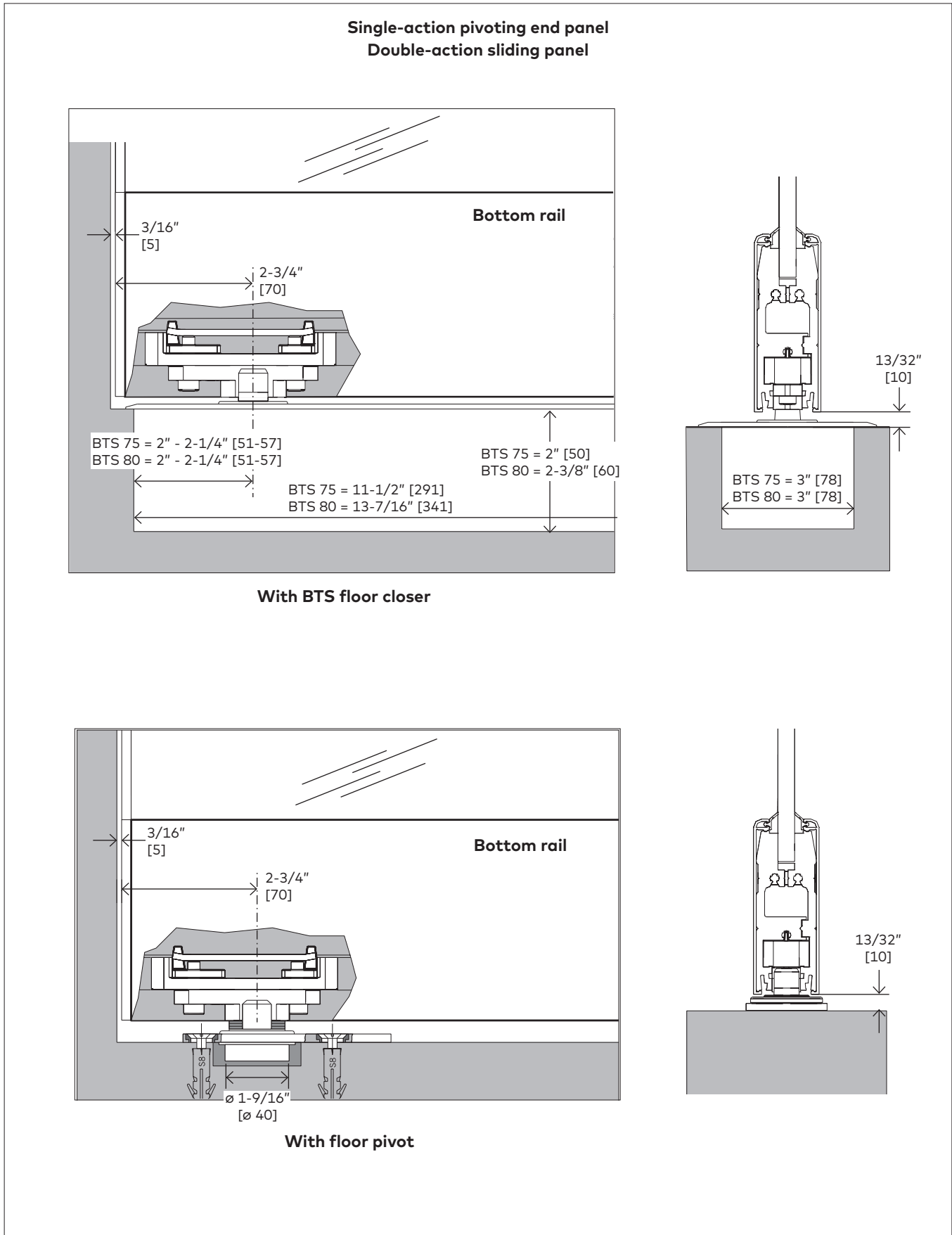

1.7 Installation options/Bottom of door components (continued)

Fig 3

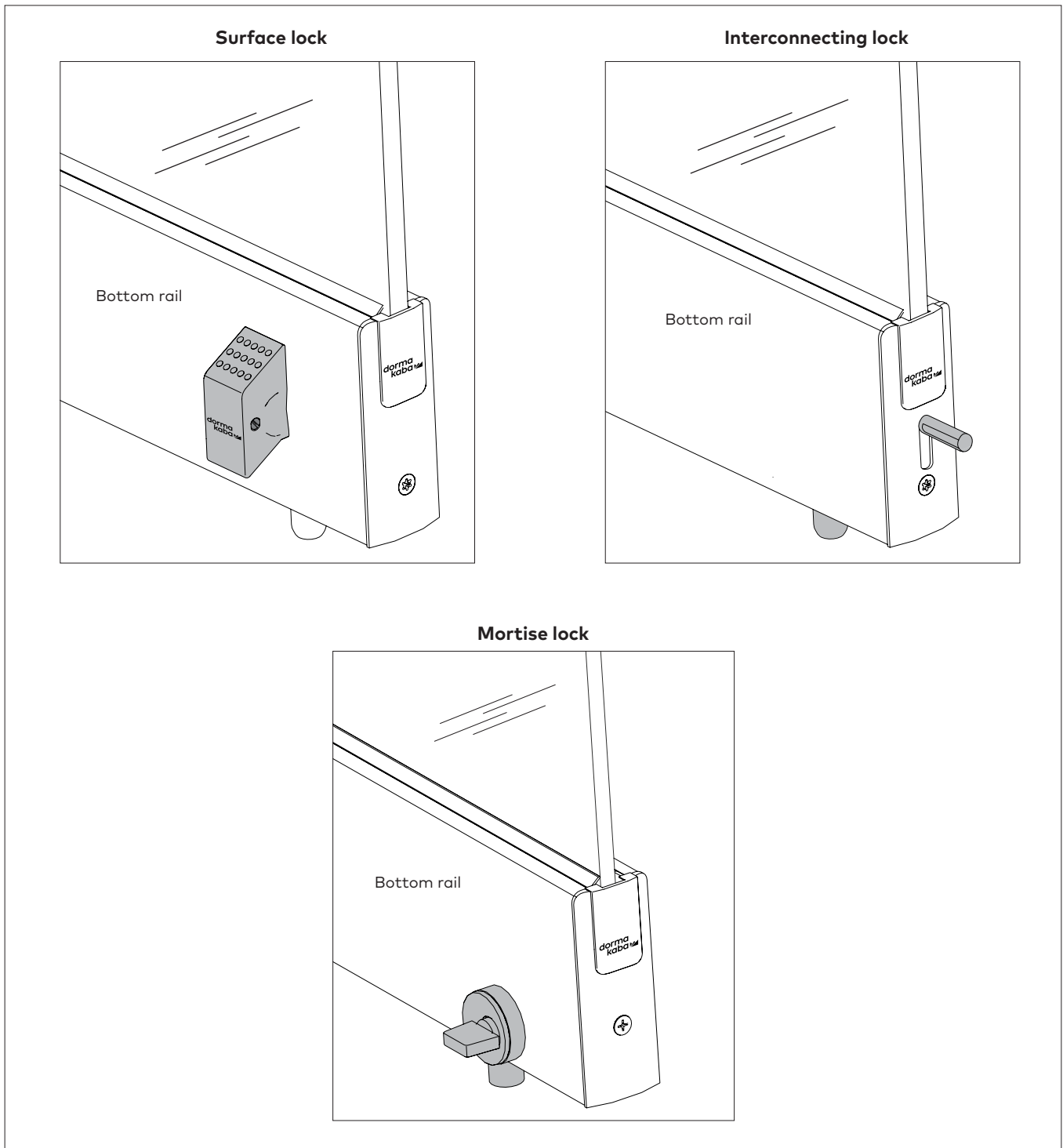

2 Installation instructions - Prepare track

2.1 Determine the track arrangement

Fig 4

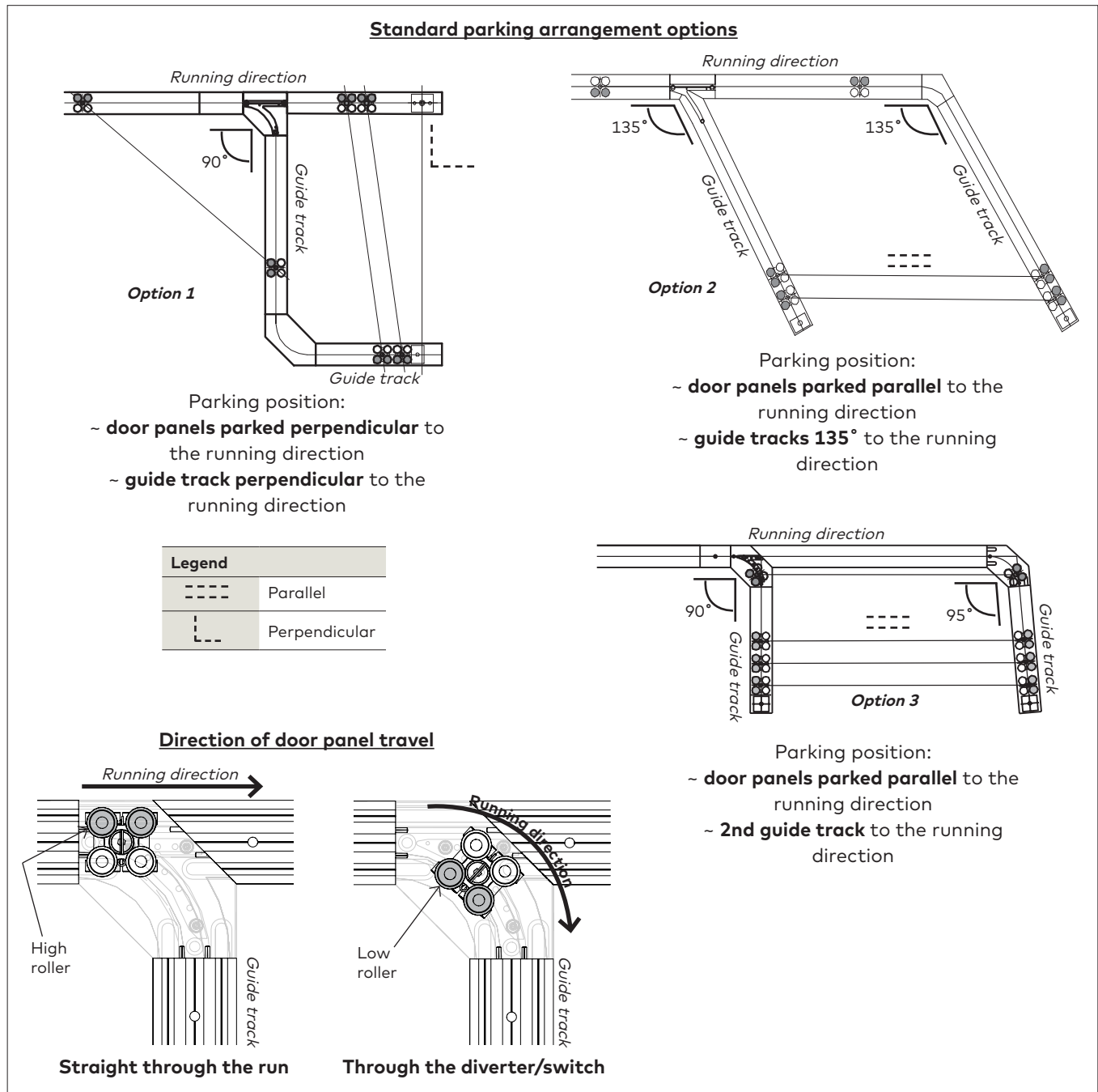

- 2.1.1 FIRST determine the following:
- parking arrangement of the door panels
 - location of the corner track (see step 2.4)
 - location of the revision piece (see step 2.4)

- 2.1.2 Note direction which doors will travel:
- Straight through the run
 - Through the diverter/switch

2.2 Install single-action pivoting end panel retaining clip

Fig 5

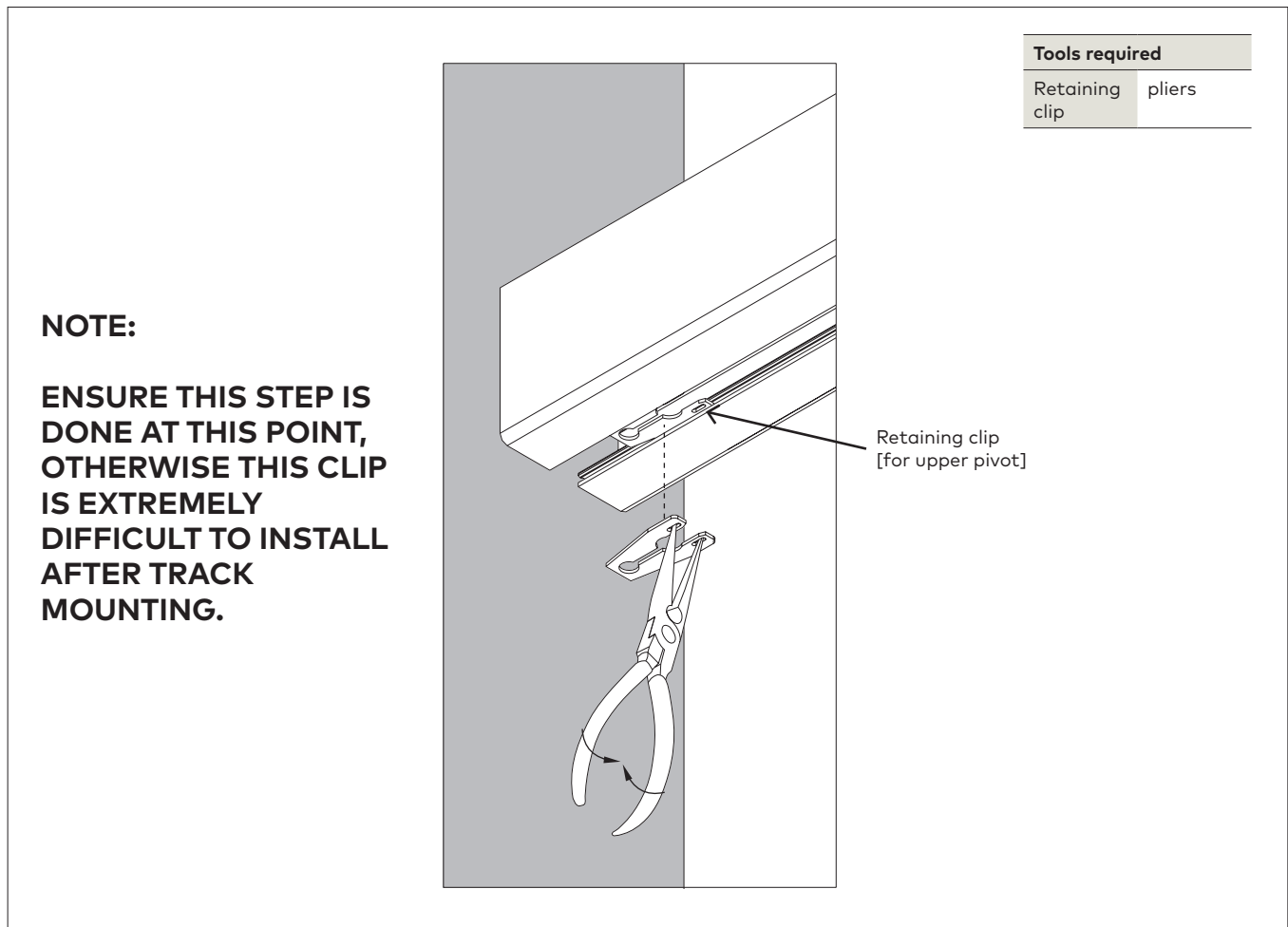

- 2.2.1 Insert retaining clip [for upper pivot] into [end of] track using pliers **prior** to mounting track to ceiling surface.

2.3 Install door track stop in stacking area

Fig 6

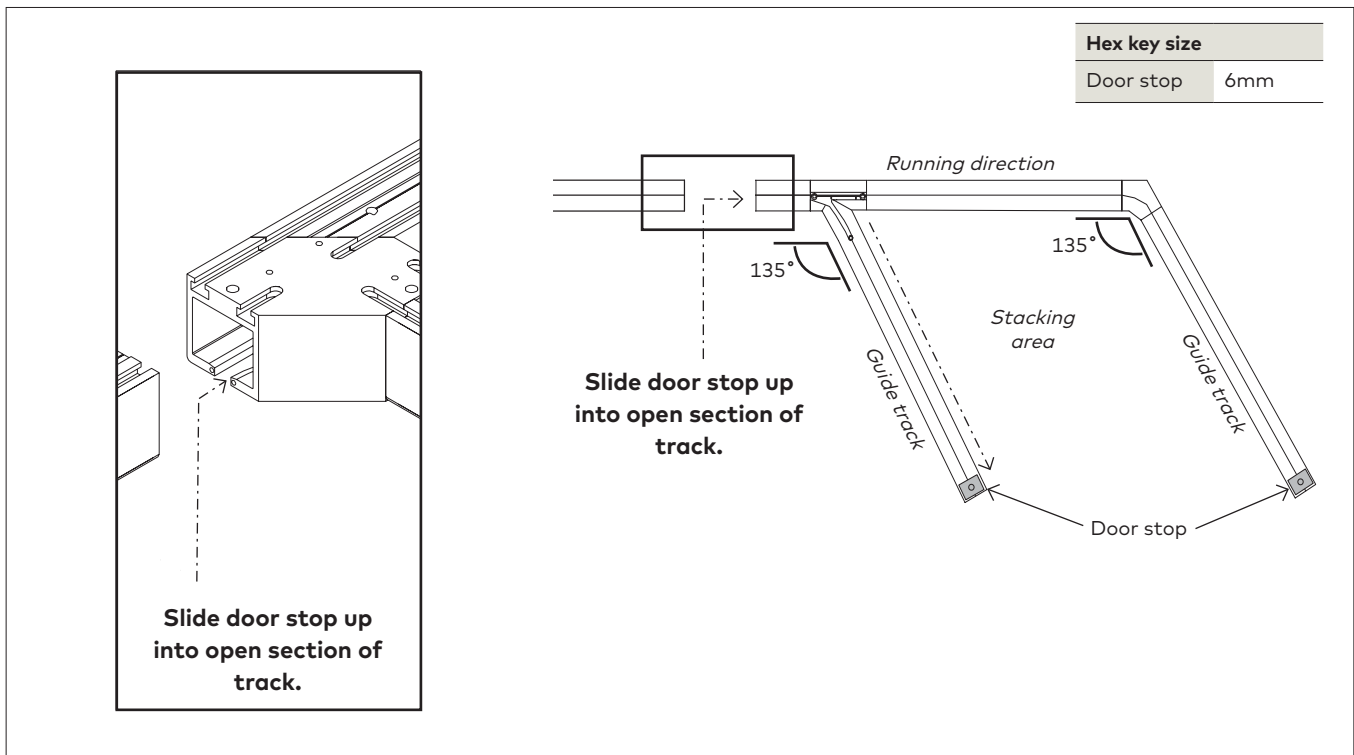

2.3.1 Slide door stop into open section of track.

2.3.2 Slide back into stacking area on opposite side of swing door pivot.

2.3.3 Secure with included fastener.

2.4 Installing the track

Fig 7

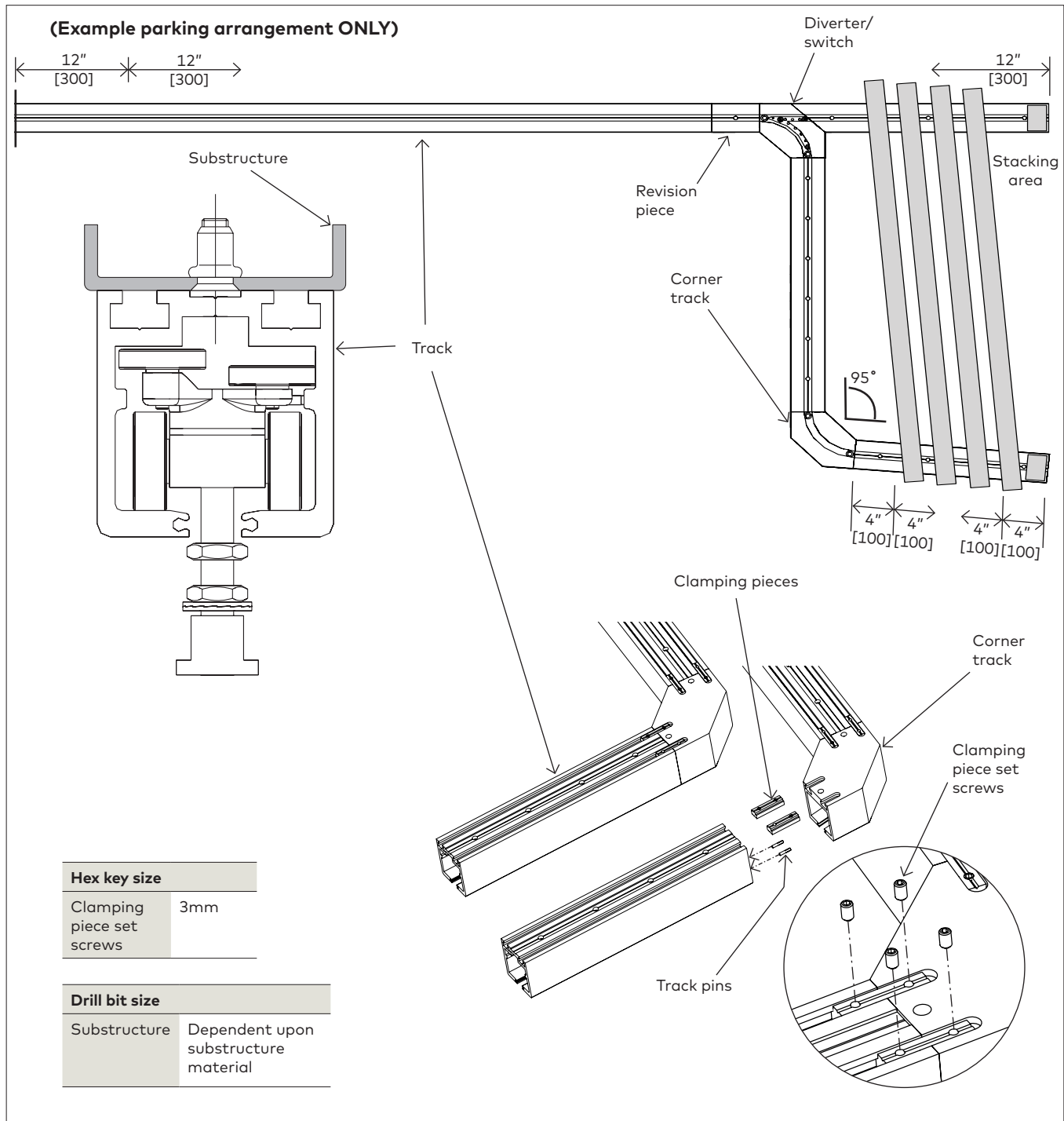

- 2.4.1 Pre-connect all straight and corner track with clamping pieces.
- 2.4.2 Slide pins inside track groove for later use.
- 2.4.3 Align track on ceiling accordingly. Mark and drill substructure hole locations.
 - **Straight run holes:** approximately 11-13/16" [300] apart
 - **Stacking area holes:** approximately 4" [100] apart

- 2.4.4 Secure the track, along its entire length, including the stacking area, to the substructure.
 - Use fasteners appropriate for substructure material.
- NOTE: REVISION PIECE IS INSTALLED IN STEP 2.7.**
- 2.4.5 Fully tighten clamping piece set screws.

2.5 Installing upper pivot block

Fig 8

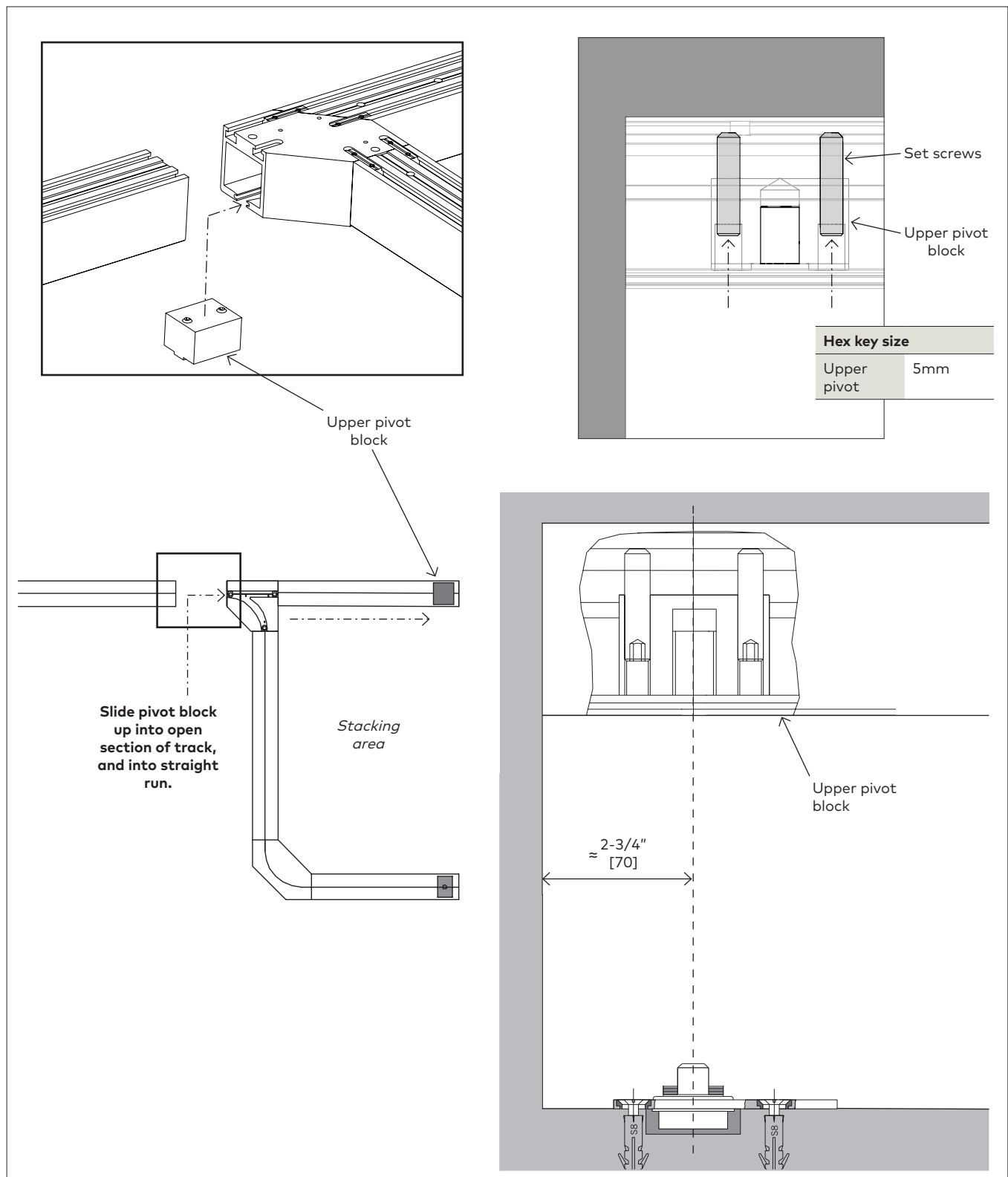

2.5.1 Slide pivot block into open section of track and into straight track run, as shown.

2.5.2 Hand tighten with set screws to hold in place.

2.5.3 Align upper pivot block with center of floor pivot/closer spindle.

2.5.4 Fully tighten set screws.

2.6 Install rollers in track

Fig 9

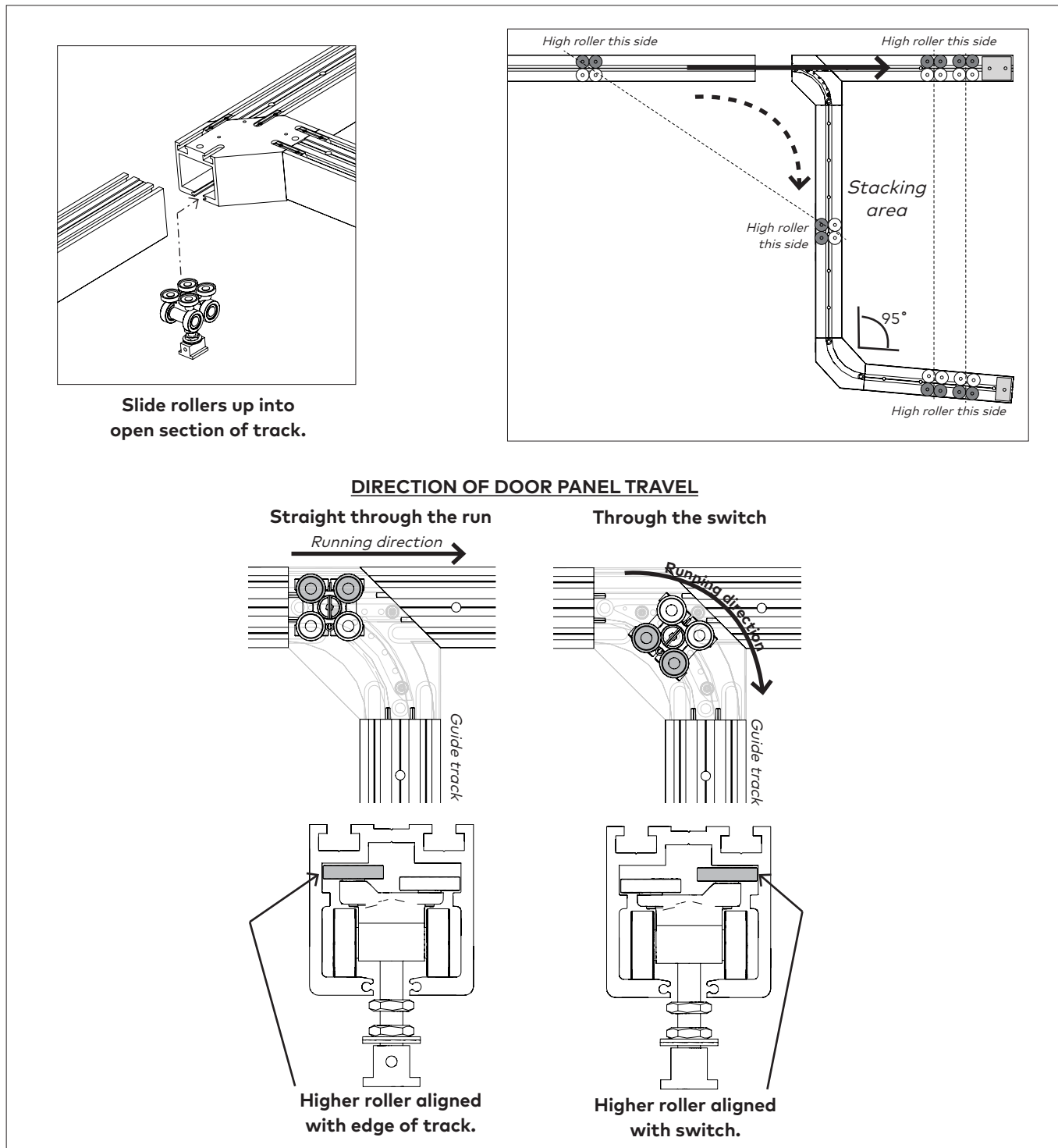

NOTE: ENSURE TRACK IS CLEAN OF SOLID DEBRIS AND GREASE.

2.6.1 Determine the arrangement of the rollers depending upon movement of panel. See images above.

NOTE: A "straight through the run" and "through the switch" roller will be needed for each panel.

2.6.2 Remove roller access, if applicable.

2.6.3 Slide rollers up through open section of track and temporarily into stacking area.

NOTE: The roller insertion [into the track] order is irrelevant; only ensure there are an equal number of properly-oriented rollers in each leg of the stacking area.

2.7 Install revision piece

Fig 10

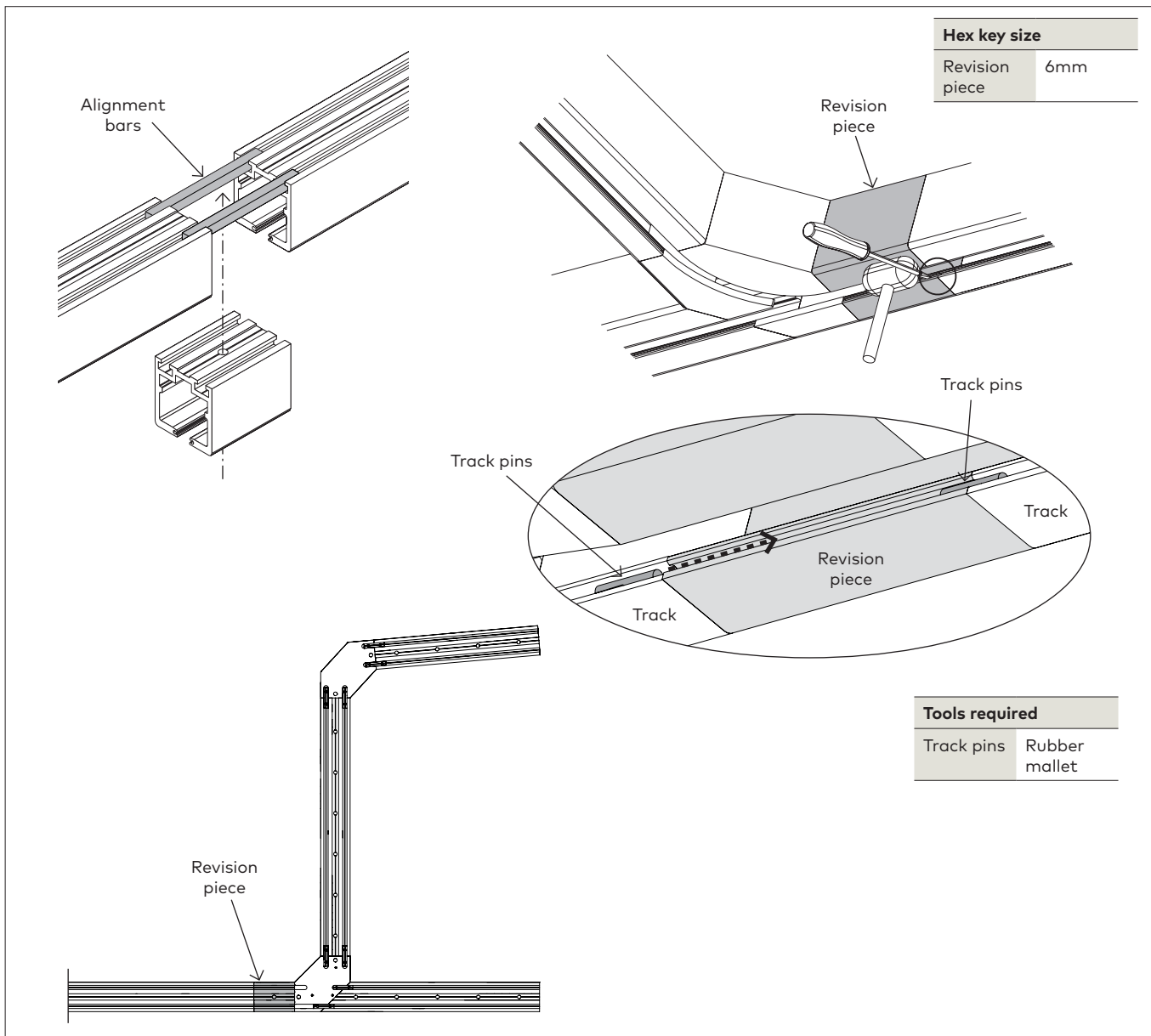

- 2.7.1 Align revision piece into track via the alignment bars in the track.
- 2.7.2 Secure using required fastener.

- 2.7.3 Using a screw driver and mallet, tap pre-installed dowels in either direction so they span across track and revision piece.

2.8 Prepare the roller pattern in the track

Fig 11

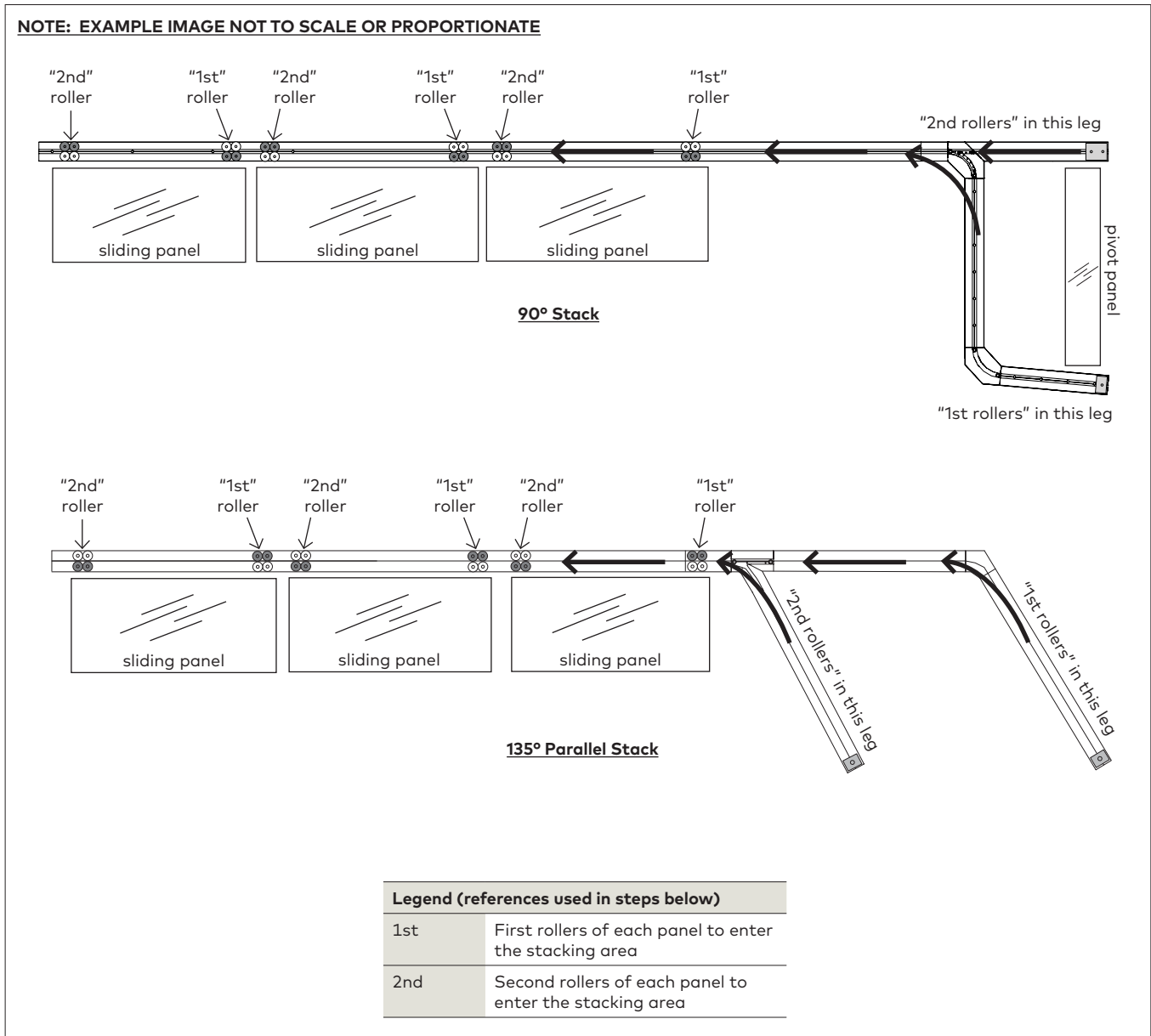

2.8.1 Slide **all** rollers out from stacking area and into straight run of track in **ALTERNATING** order listed below:

- Always slide **a pair** of rollers for each panel:
 - » one "1st" roller and one "2nd" roller
 - » **ALWAYS SLIDE THE "2nd" ROLLERS OUT (FOR EACH PANEL) FIRST.**

3 Installation instructions - DA & SA pivoting end panel

3.1 Preparing the DA & SA pivoting end panel (with monolithic glass only)

Fig 12

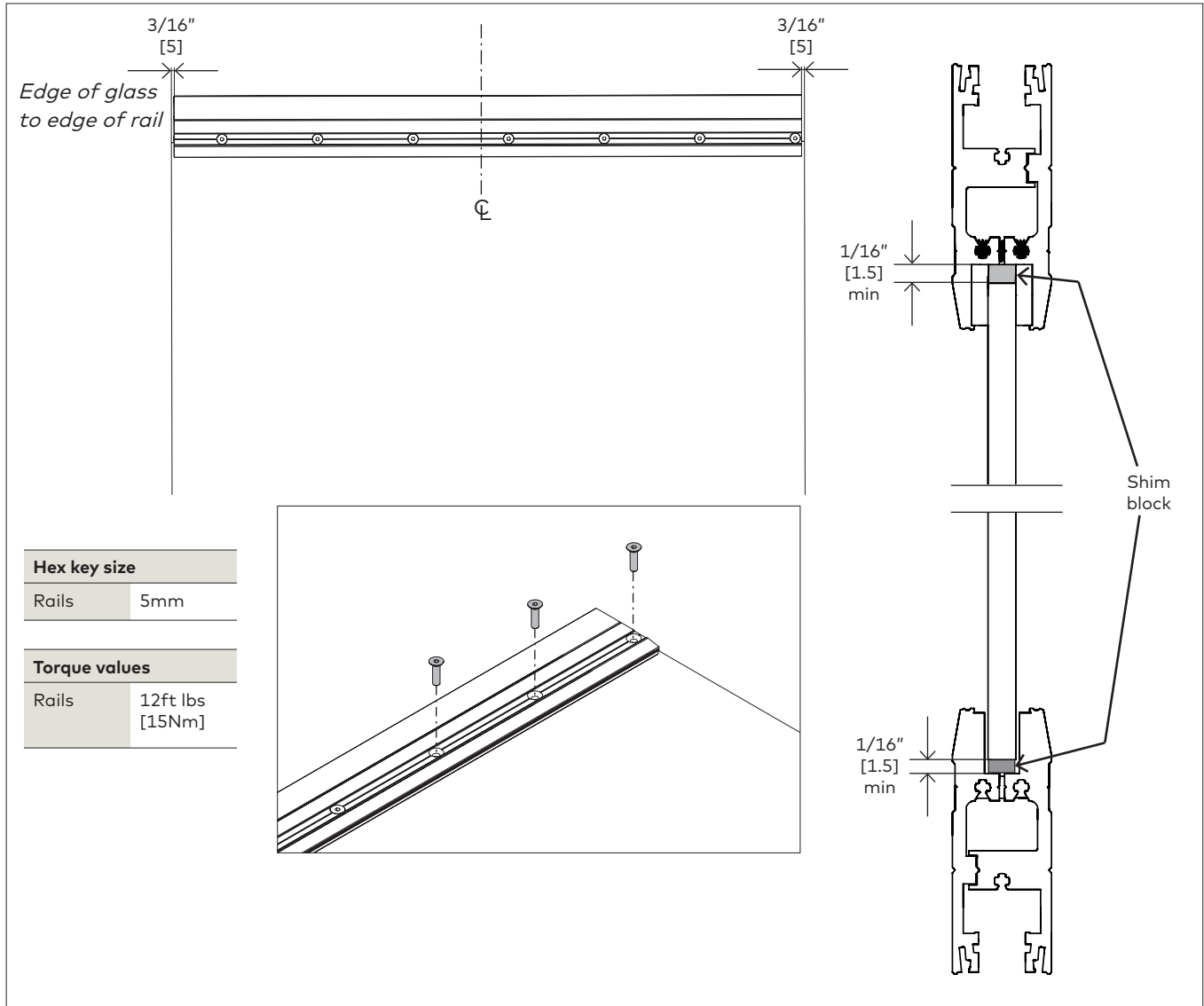

- ⚠ NOTE: FULLY CLEAN SURFACE OF GLASS WITH AN ALCOHOL-BASED MILD GLASS AND SURFACE CLEANER.**
- ⚠ ENSURE RAIL GASKET IS FREE OF DEBRIS.**
- ⚠ NOTE: ENSURE RAILS ARE SQUARE PRIOR TO HANGING DOOR TO AVOID EXCESSIVE DOOR ADJUSTMENT ONCE PANEL IS INSTALLED. MEASURE FOR CORRECT PANEL HEIGHT.**

3.1.1 Lay glass panel on a flat surface.

3.1.1 Loosen rail screws.

NOTE: If bottom rail contains locking mechanism, ensure rail is in proper orientation for lock usage.

3.1.2 Slide rails onto top and bottom of glass panel.

NOTE: Place shim blocks in bottom rail.

3.1.3 Fully tighten and torque rail screws.

3.2 Preparing the DA & SA pivoting end panel (with tempered laminated glass only)

Fig 13

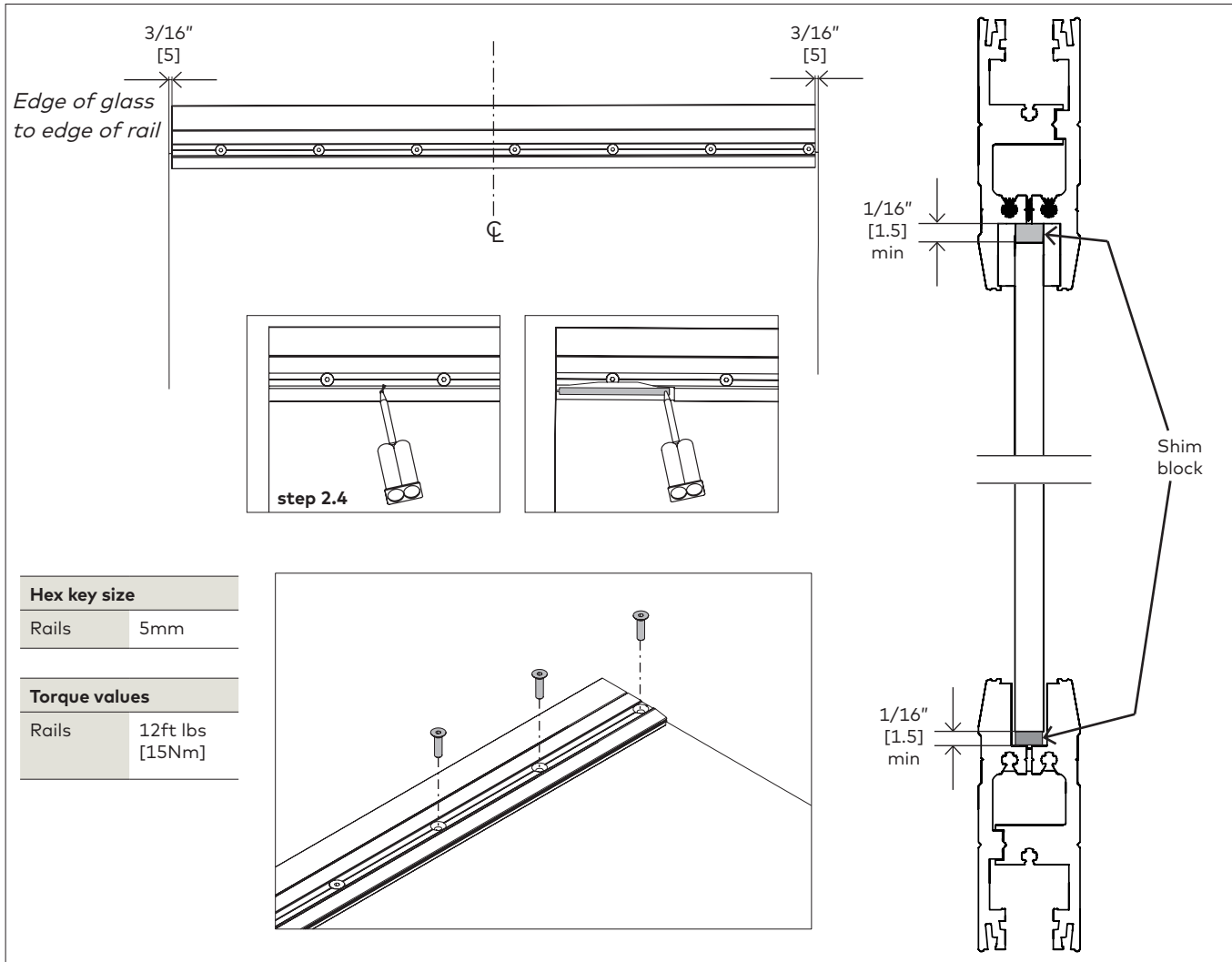

- ⚠ NOTE: THE RECOMMENDED ADHESIVE'S SET-UP TIME IS 20 MINUTES FOR THE DUO-PAK CARTRIDGES.**
- ⚠ NOTE: USE 1:1 RATIO PLUNGER WITH THE 3M™ Scotch-Weld™ Urethane Adhesive.**
- ⚠ NOTE: FULLY CLEAN SURFACE OF GLASS WITH AN ALCOHOL-BASED MILD GLASS AND SURFACE CLEANER. ENSURE NO DEBRIS IS ON THE GASKET.**
- ⚠ NOTE: ENSURE RAILS ARE SQUARE PRIOR TO SECURING WITH ADHESIVE DOOR TO AVOID EXCESSIVE DOOR ADJUSTMENT ONCE PANEL IS INSTALLED. MEASURE FOR CORRECT PANEL HEIGHT.**

- 3.2.1 Lay glass panel on a flat surface.
- 3.2.1 Loosen rail screws.
- NOTE: If bottom rail contains locking mechanism, ensure rail is in proper orientation for lock usage.**
- 3.2.2 Slide rails onto top and bottom of glass panel.
- NOTE: Place shim blocks in bottom rail.**
- 3.2.3 Fully tighten and torque rail screws.

NOTE: Onto scrap material, first dispense approximately 12" of 3M™ Scotch-Weld™ Urethane Adhesive prior to application to prevent mixing errors and ensure optimal hardening.

- 3.2.4 Dispense into filling holes in rails.
- ⚠ Stop application when adhesive can be seen past edge of rail.**

⚠ DO NOT WIPE any excess adhesive from glass surface. Allow adhesive to dry and scrape off glass surface with a beveled-edge chisel or putty knife.

3.3 Preparing the upper pivot block

Fig 14

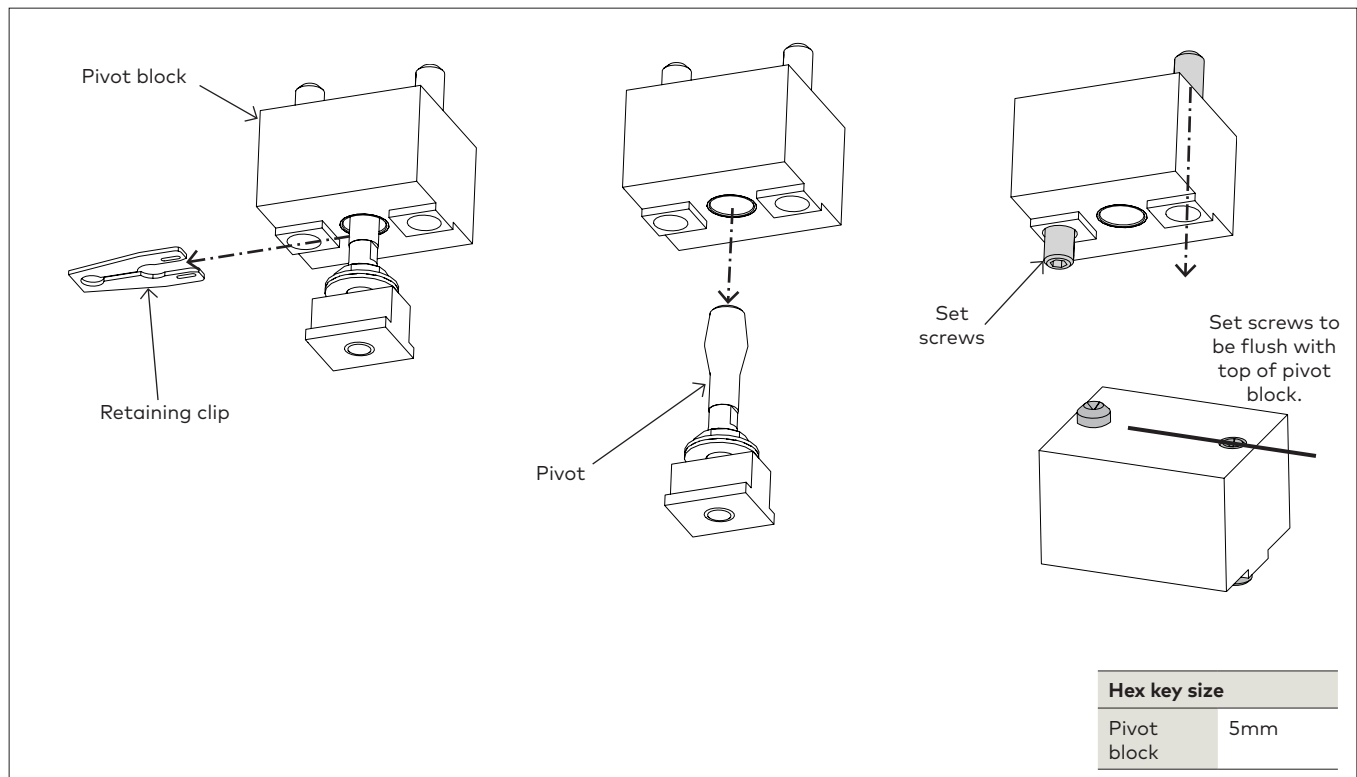

- 3.3.1 (Retaining clip removed in step 2.2.)
- 3.3.2 Slide the pivot from the pivot block. (Set aside.)

- 3.3.3 Loosen set screws and make flush with top of pivot block.

3.4 Install floor pivot or BTS80 closer

Fig 15

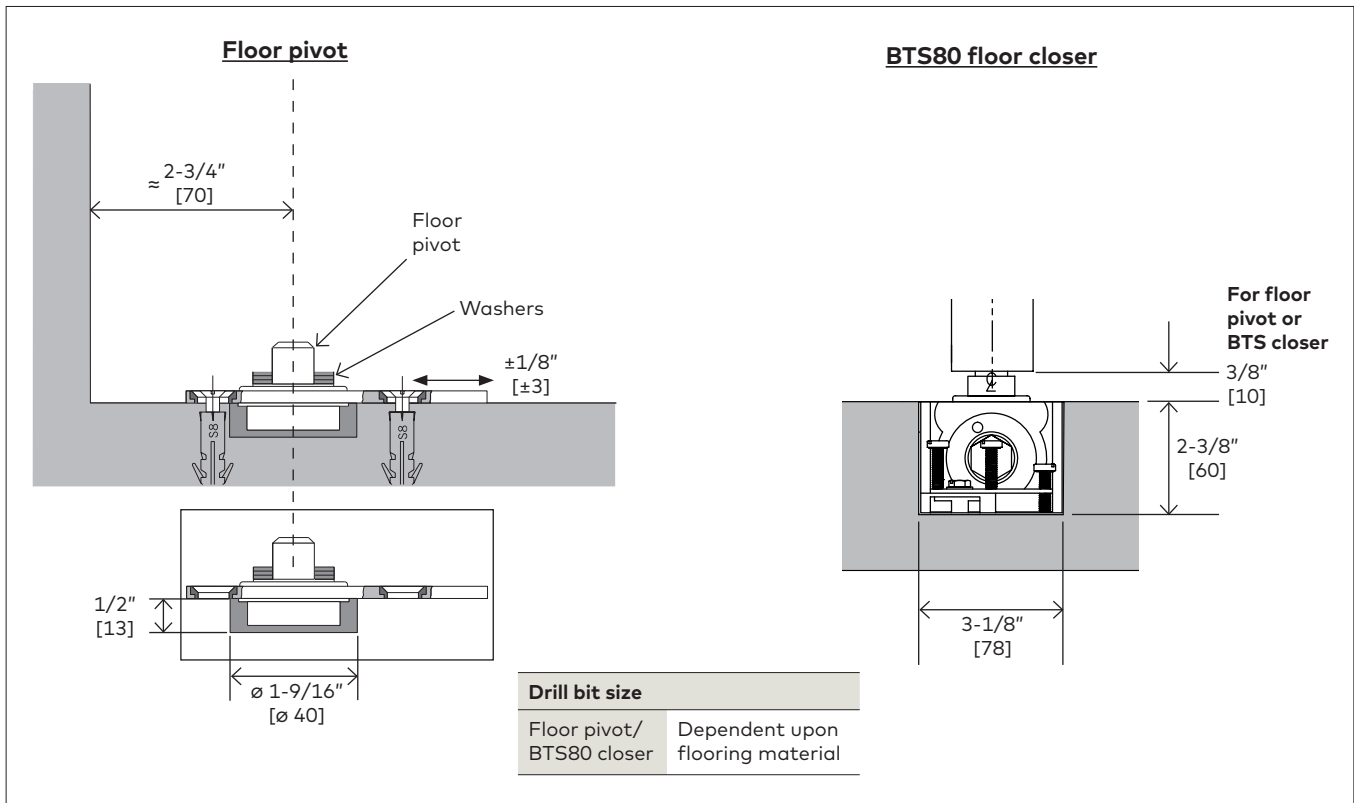

3.4.1 Align floor pivot or BTS80 closer 2-3/4" [70] from door jamb.

3.4.2 (Floor pivot): Use 3 included washers to create appropriate door spacing.

Ensure pivot/closer are plumb and level.

3.4.3 Mark and drill holes, and recess into flooring surface.

3.4.4 (Floor pivot): Insert anchors if necessary.

3.4.5 Secure pivot/BTS closer to floor surface using appropriate fasteners.

3.5 Install pivot into end panel carrier profile

Fig 16

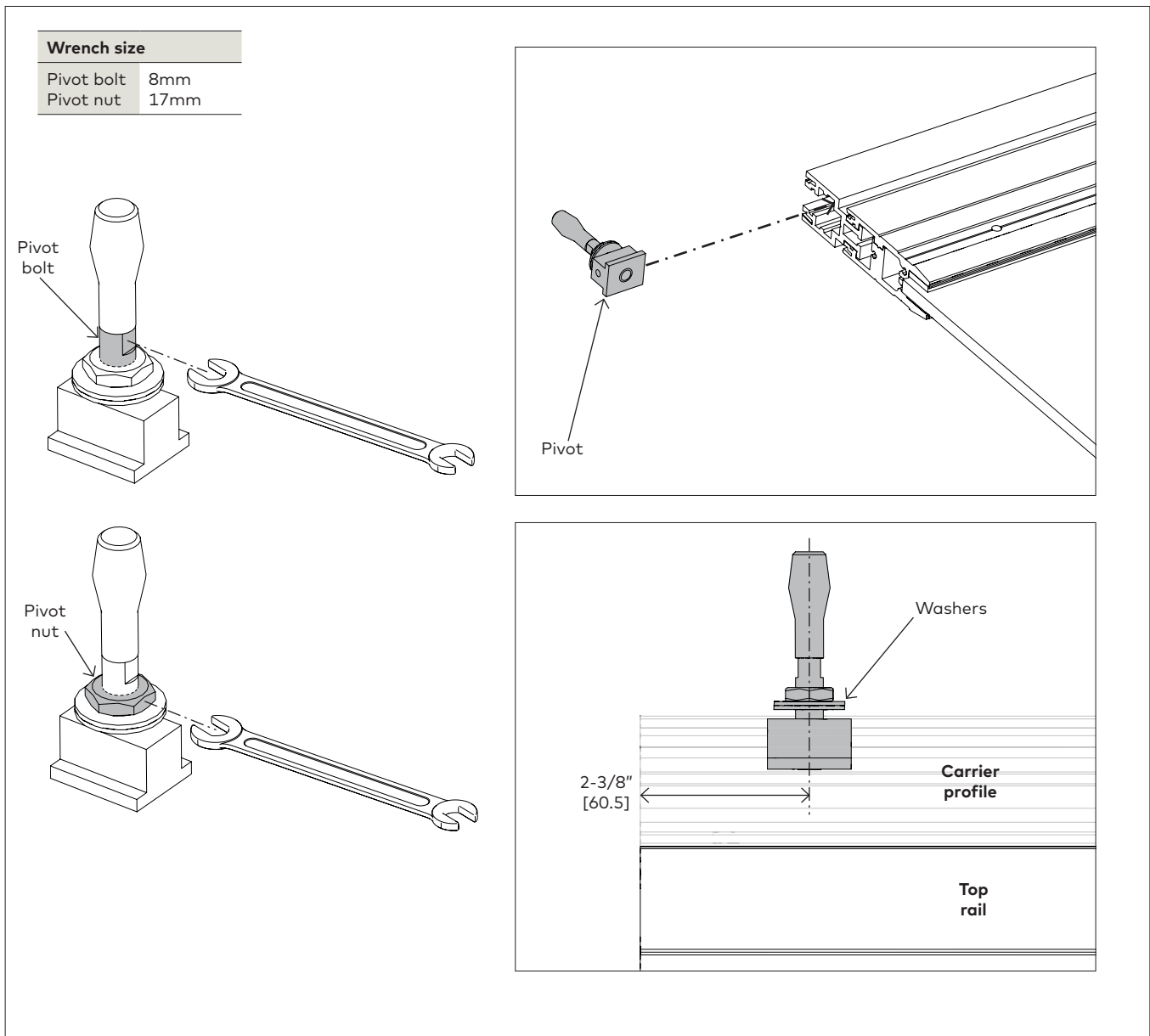

- 3.6.1 Loosen nut.
- 3.5.2 Lower bolt by rotating to allow for clearance.

- 3.5.3 Slide pivot into carrier profile as shown. **NOTE: Ensure washers are above carrier profile.**
- 3.6.4 Set pivot at 2-3/8" [60.5] from end of rail.

3.6 Install top cover gasket

Fig 17

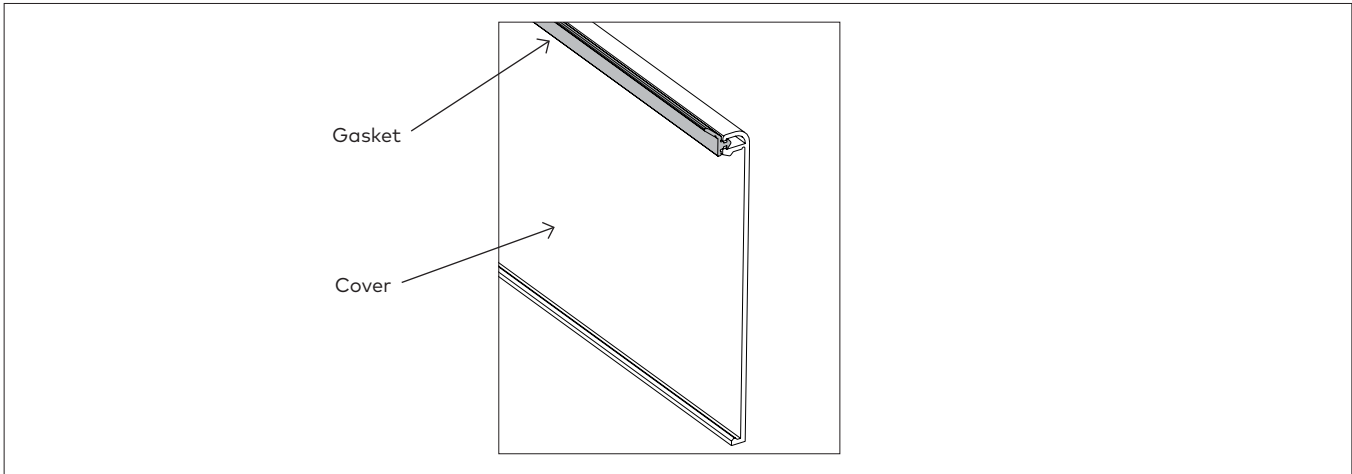

3.6.1 Push gasket into top cover.

3.7 Installing top covers

Fig 18

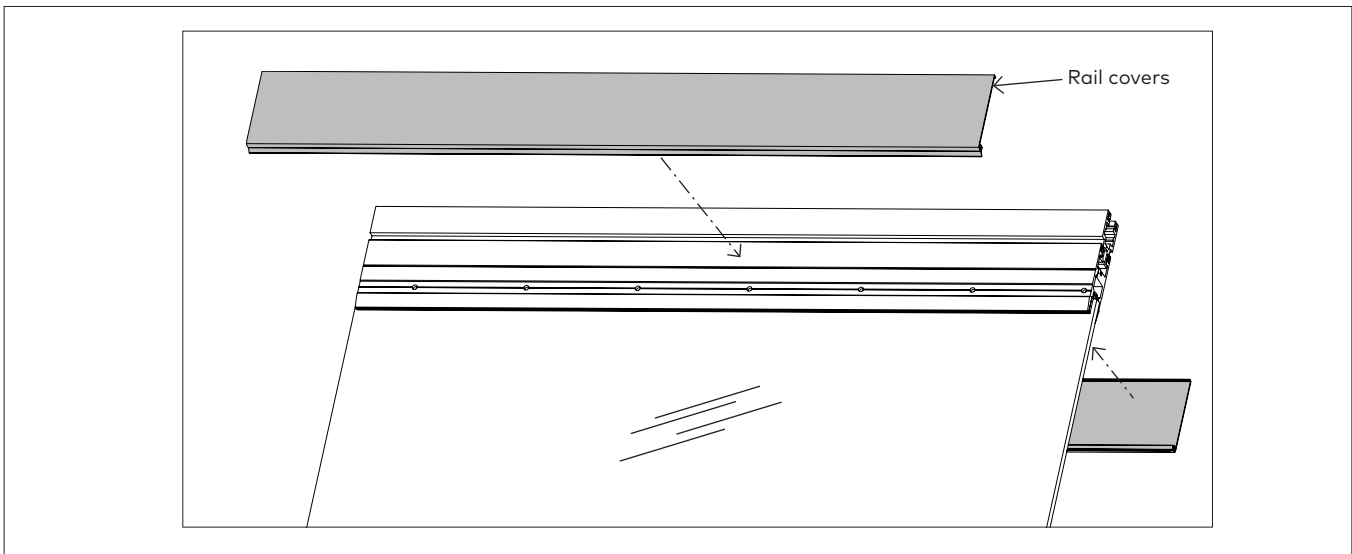

3.7.1 Snap covers onto rails.

3.8 Install DA & SA pivoting end panel into track

Fig 19

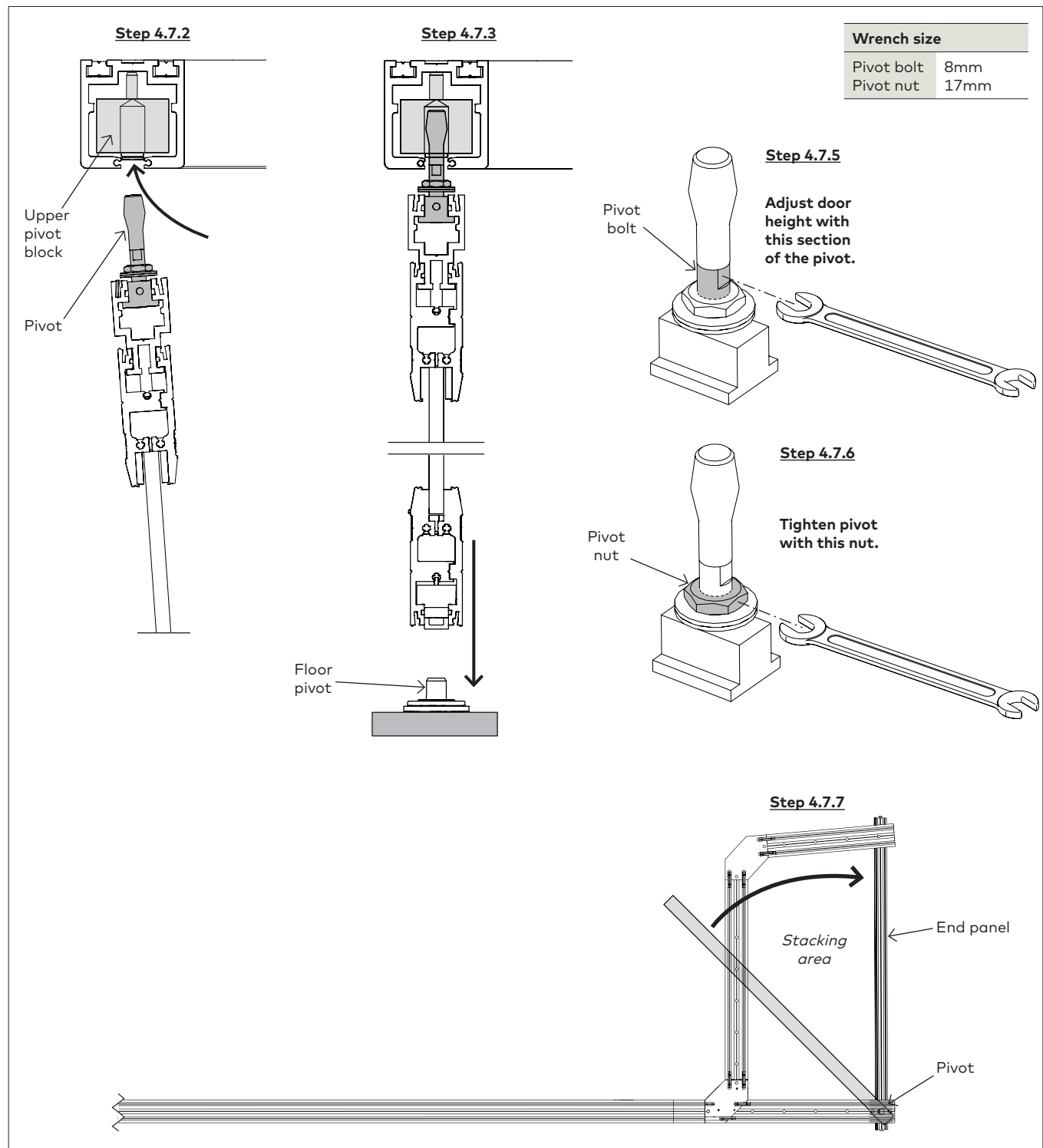

- 3.8.1 Rest assembled panel on 3/8" [10] shim blocks.
- 3.8.2 Lower pivot pin down as far as it will go.
- 3.8.3 Tip glass and pivot up into upper pivot block.
- 3.8.4 Lower down onto floor pivot.

- 3.8.5 **Ensure door is plumb and level.**
- 3.8.6 Adjust door height up or down accordingly.
- 3.8.7 Tighten upper pivot block in place.
- 3.8.8 Rotate door into stacking area.

3.9 Secure end panel in track

Fig 20

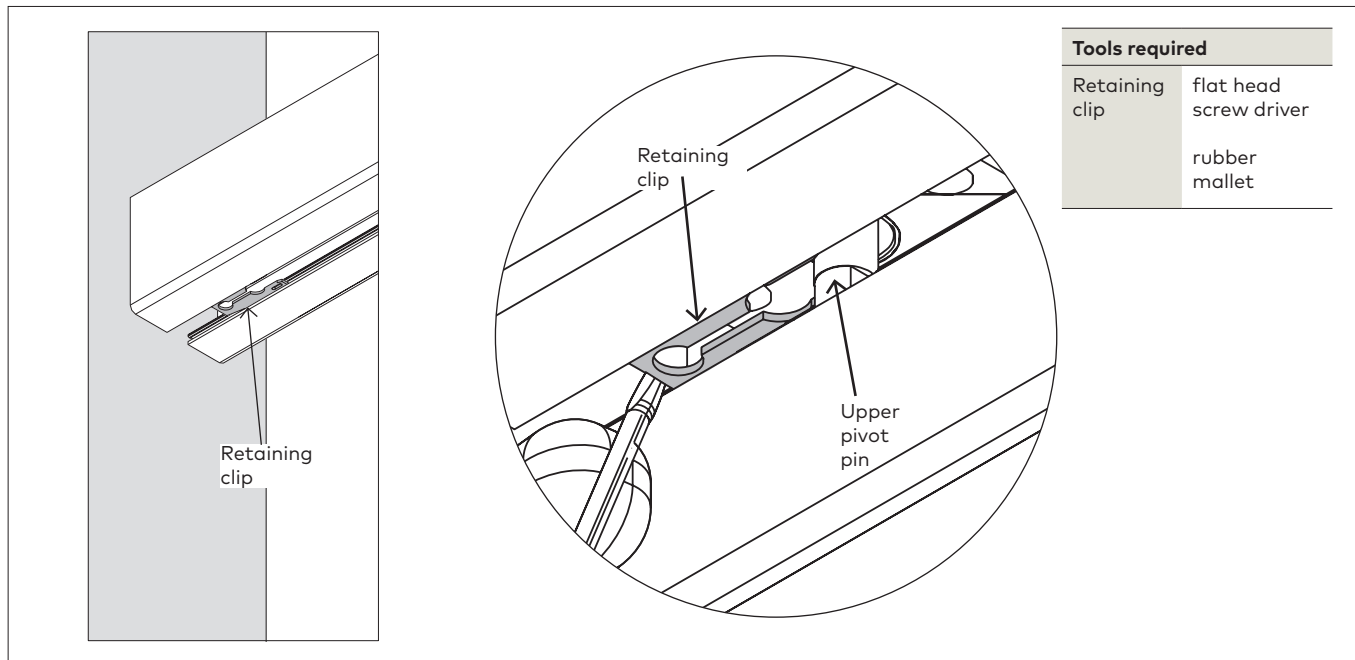

- 3.9.1 Slide retaining clip inside track groove and tap/ snap into place around upper pivot pin.
- Use screw driver and rubber mallet.

4 Installation instructions - Sliding panel

4.1 Preparing the sliding panel (with monolithic glass only)

Fig 21

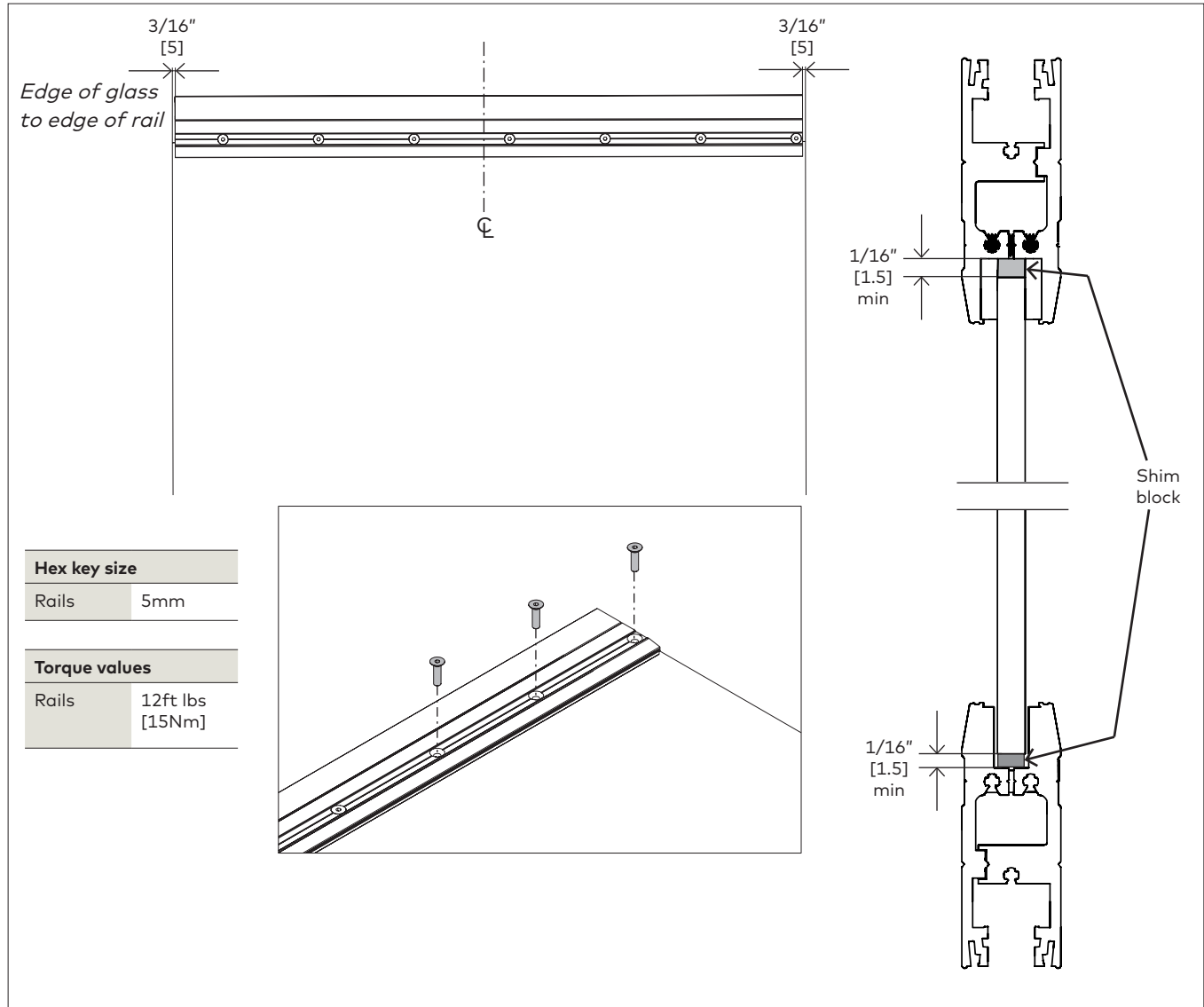

- ⚠ NOTE: FULLY CLEAN SURFACE OF GLASS WITH AN ALCOHOL-BASED MILD GLASS AND SURFACE CLEANER.**
- ⚠ ENSURE RAIL GASKET IS FREE OF DEBRIS.**
- ⚠ NOTE: ENSURE RAILS ARE SQUARE PRIOR TO HANGING DOOR TO AVOID EXCESSIVE DOOR ADJUSTMENT ONCE PANEL IS INSTALLED. MEASURE FOR CORRECT PANEL HEIGHT.**

- 4.1.1 Lay glass panel on a flat surface.
- 4.1.1 Loosen rail screws.
- NOTE: If bottom rail contains locking mechanism, ensure rail is in proper orientation for lock usage.**
- 4.1.2 Slide rails onto top and bottom of glass panel.
- NOTE: Place shim blocks in bottom rail.**
- 4.1.3 Fully tighten and torque rail screws.

4.2 Preparing the sliding panel (with tempered laminated glass only)

Fig 22

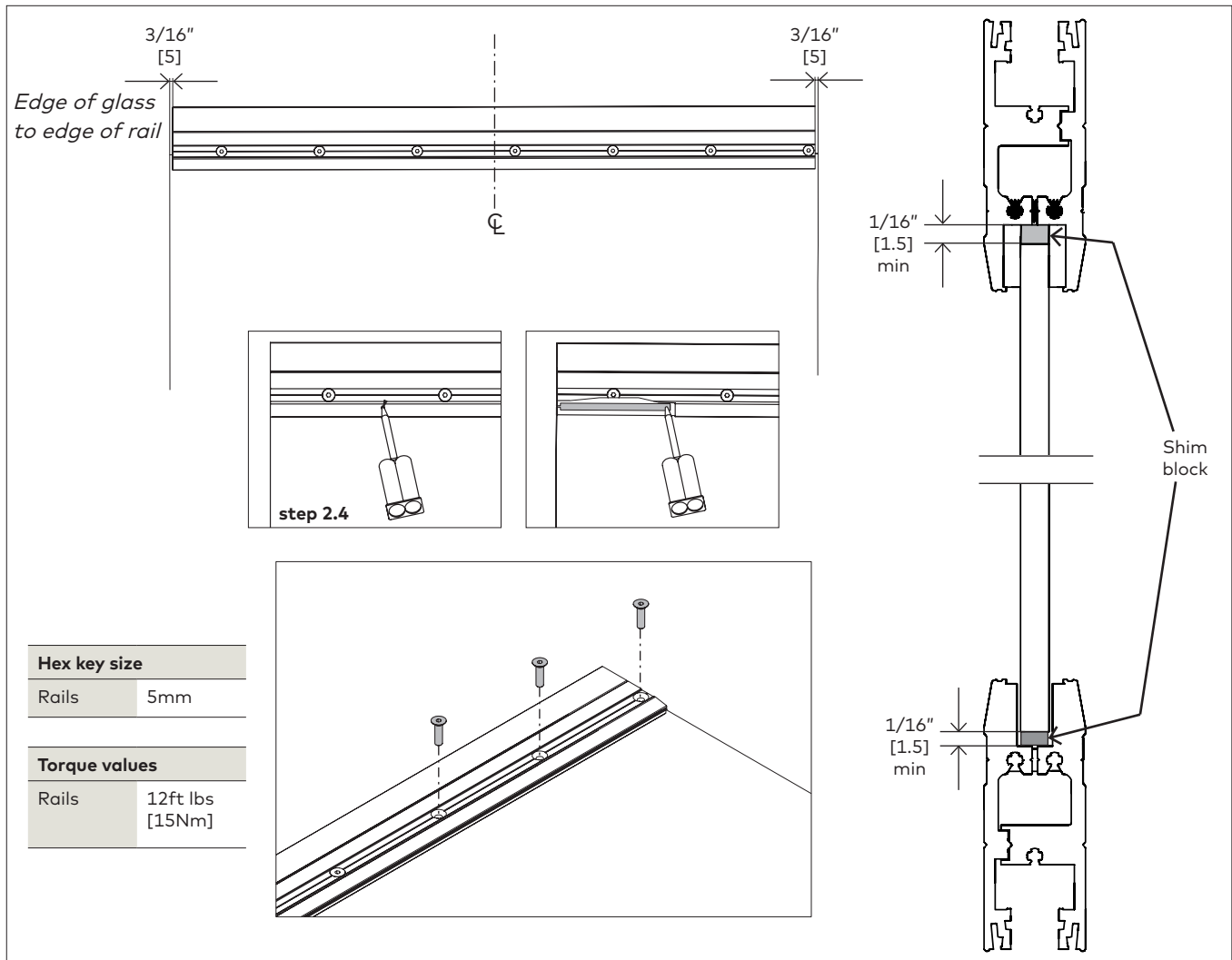

Hex key size	
Rails	5mm

Torque values	
Rails	12ft lbs [15Nm]

- ⚠ NOTE: THE RECOMMENDED ADHESIVE'S SET-UP TIME IS 20 MINUTES FOR THE DUO-PAK CARTRIDGES.**
- ⚠ NOTE: USE 1:1 RATIO PLUNGER WITH THE 3M™ Scotch-Weld™ Urethane Adhesive.**
- ⚠ NOTE: FULLY CLEAN SURFACE OF GLASS WITH AN ALCOHOL-BASED MILD GLASS AND SURFACE CLEANER. ENSURE NO DEBRIS IS ON THE GASKET.**
- ⚠ NOTE: ENSURE RAILS ARE SQUARE PRIOR TO SECURING WITH ADHESIVE TO AVOID EXCESSIVE DOOR ADJUSTMENT ONCE PANEL IS INSTALLED. MEASURE FOR CORRECT PANEL HEIGHT.**

- 4.2.1 Lay glass panel on a flat surface.
- 4.2.1 Loosen rail screws.
- NOTE: If bottom rail contains locking mechanism, ensure rail is in proper orientation for lock usage.**
- 4.2.2 Slide rails onto top and bottom of glass panel.
- NOTE: Place shim blocks in bottom rail.**
- 4.2.3 Fully tighten and torque rail screws.

NOTE: Onto scrap material, first dispense approximately 12" of 3M™ Scotch-Weld™ Urethane Adhesive prior to application to prevent mixing errors and ensure optimal hardening.

- 4.2.4 Dispense into filling holes in rails.
- ⚠** Stop application when adhesive can be seen past edge of rail.
- ⚠** DO NOT WIPE any excess adhesive from glass surface. Allow adhesive to dry and scrape off glass surface with a beveled-edge chisel or putty knife.

4.3 Install sliding panel onto rollers and adjust door height

Fig 23

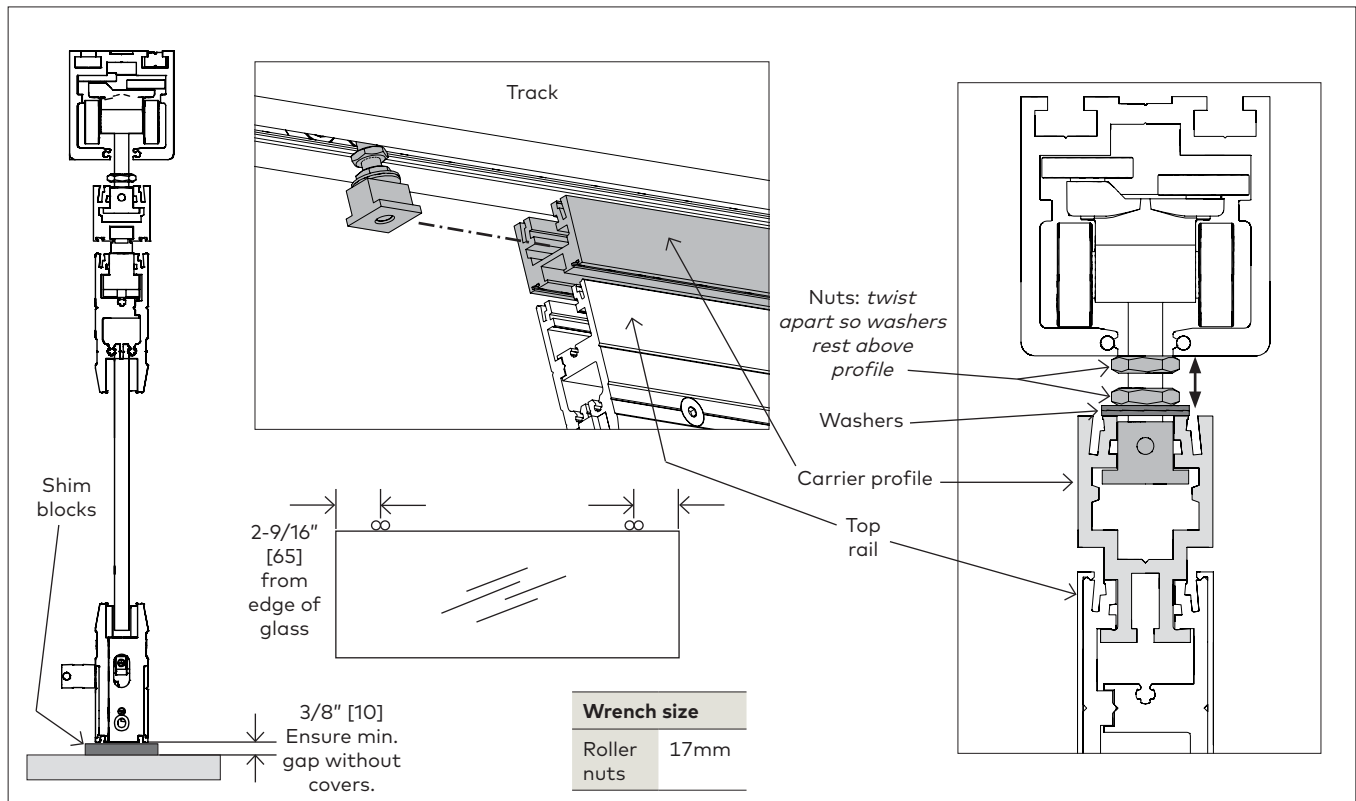

- 4.3.1 Rest glass panel on 3/8" [10] shim blocks.
 - 4.3.2 Ensure one roller is on each side of panel.
 - 4.3.3 Insert rollers into carrier profile:
 - **REFER TO STEP 2.8 FOR ROLLER PATTERN.**
 - Twist nuts apart such that **washers** will rest **above** carrier profile.
 - **Sliding panels:** slide one roller into each end of the carrier profile. (a "2nd" and a "1st" for each)
- NOTE:** For perpendicular stacking: center of "2nd" roller must be 2-9/16" [65] from edge of glass.
- NOTE:** For parallel stacking: roller are adjustable.

- 4.3.4 Slide panels into stacking area, and allow "1st" roller to naturally settle into place within the carrier profile.
- 4.3.5 Then, slide all panels out into the straight run again for horizontal adjustment.
- 4.3.6 **Adjust door height:**
 - Loosen lower nut.
 - Rotate upper nut to raise or lower door.
 - **Ensure a minimum 3/8" [10] gap between bottom of door and floor (without covers).**
- 4.3.7 DO **NOT** FULLY TIGHTEN NUTS AT THIS POINT.

4.4 Install gasket and top cover

Fig 24

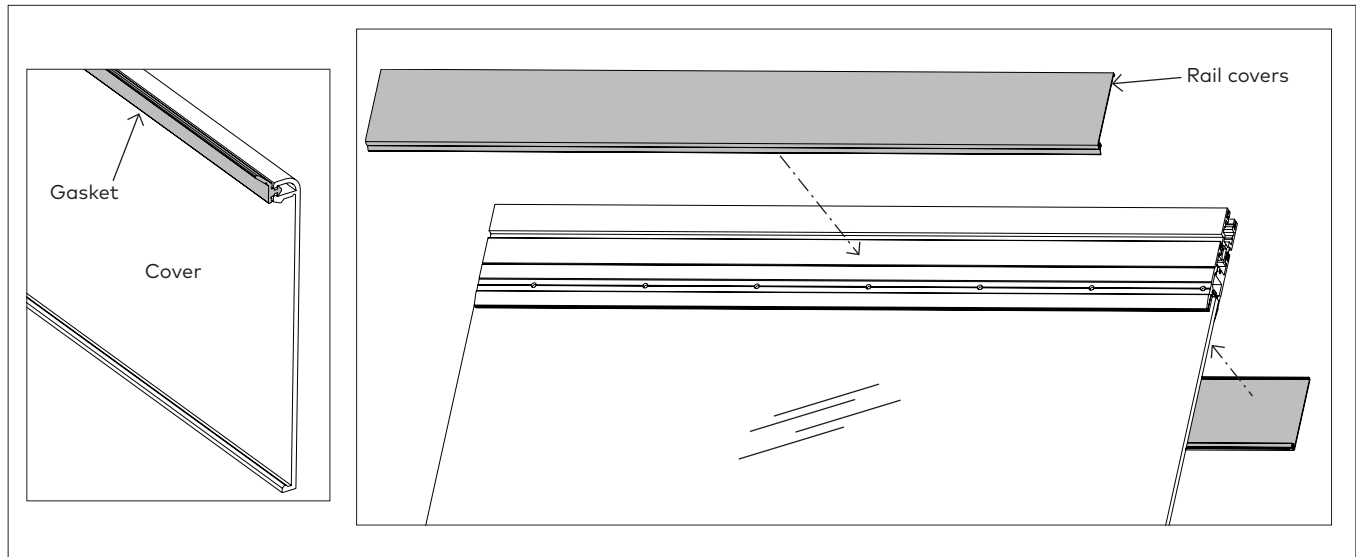

4.4.1 Push gasket into top cover.

4.4.2 Snap covers onto rails.

5 Installation instructions - Double-action sliding panel with ITS96

5.1 Preparing the DA sliding panel (with monolithic glass)

Fig 25

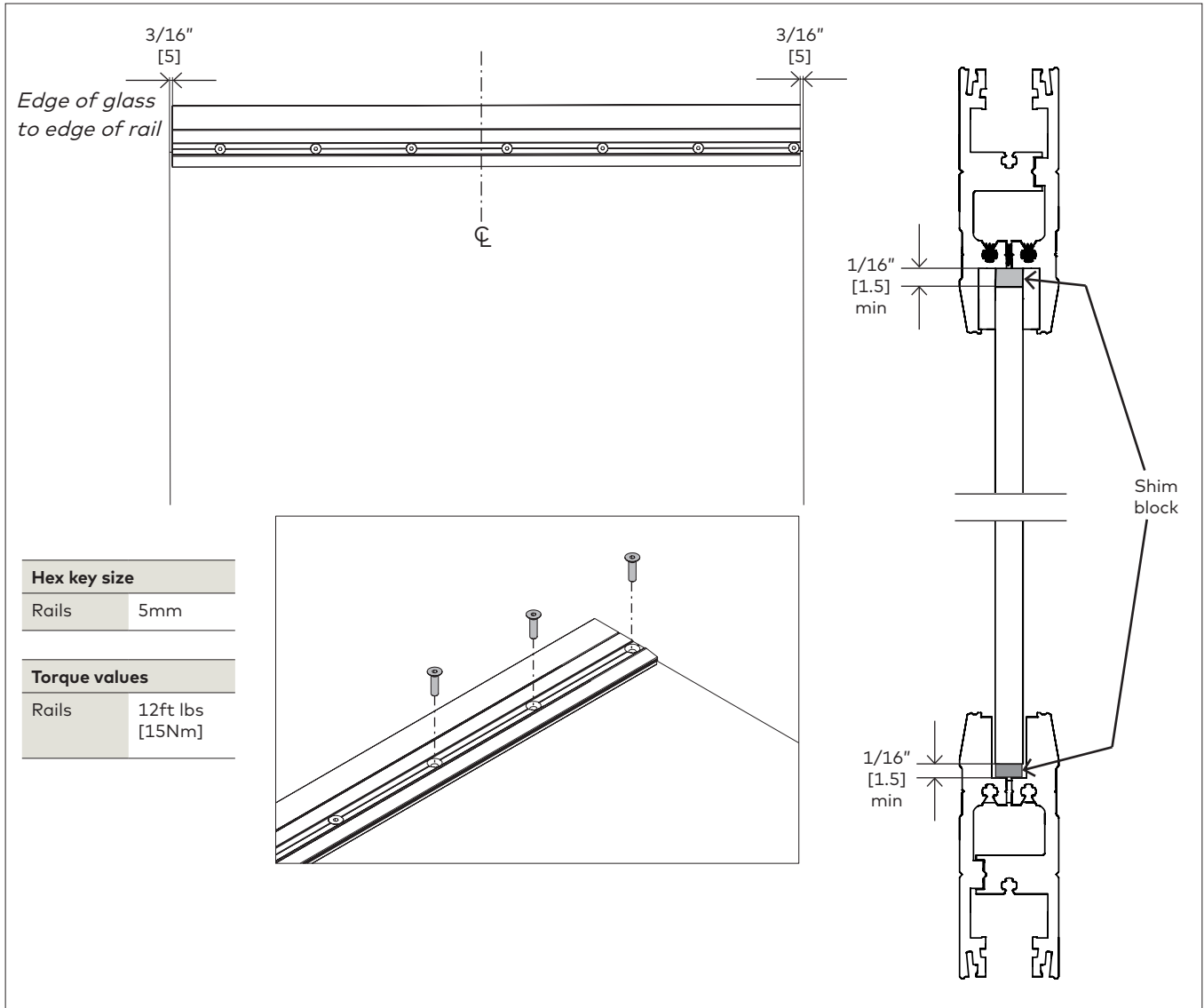

- ⚠ NOTE: FULLY CLEAN SURFACE OF GLASS WITH AN ALCOHOL-BASED MILD GLASS AND SURFACE CLEANER.**
- ⚠ ENSURE RAIL GASKET IS FREE OF DEBRIS.**
- ⚠ NOTE: ENSURE RAILS ARE SQUARE PRIOR TO HANGING DOOR TO AVOID EXCESSIVE DOOR ADJUSTMENT ONCE PANEL IS INSTALLED. MEASURE FOR CORRECT PANEL HEIGHT.**

- 5.1.1 Lay glass panel on a flat surface.
- 5.1.1 Loosen rail screws.
- NOTE: If bottom rail contains locking mechanism, ensure rail is in proper orientation for lock usage.**
- 5.1.2 Slide rails onto top and bottom of glass panel.
- NOTE: Place shim blocks in bottom rail.**
- 5.1.3 Fully tighten and torque rail screws.

5.2 Preparing the DA sliding panel (with tempered laminated glass only)

Fig 26

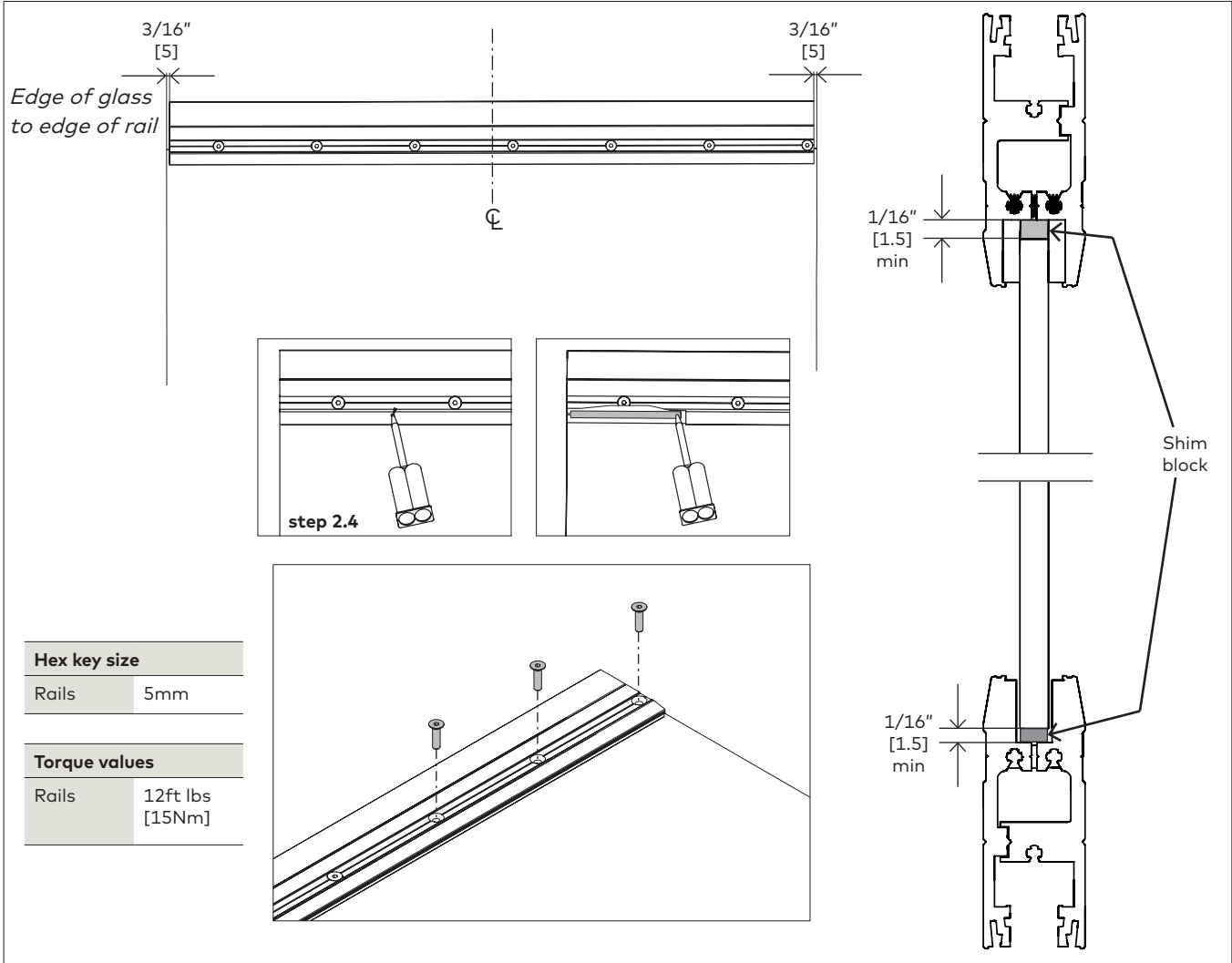

⚠ NOTE: THE RECOMMENDED ADHESIVE'S SET-UP TIME IS 20 MINUTES FOR THE DUO-PAK CARTRIDGES.

⚠ NOTE: USE 1:1 RATIO PLUNGER WITH THE 3M™ Scotch-Weld™ Urethane Adhesive.

⚠ NOTE: FULLY CLEAN SURFACE OF GLASS WITH AN ALCOHOL-BASED MILD GLASS AND SURFACE CLEANER. ENSURE NO DEBRIS IS ON THE GASKET.

⚠ NOTE: ENSURE RAILS ARE SQUARE PRIOR TO SECURING WITH ADHESIVE TO AVOID EXCESSIVE DOOR ADJUSTMENT ONCE PANEL IS INSTALLED. MEASURE FOR CORRECT PANEL HEIGHT.

5.2.1 Lay glass panel on a flat surface.

5.2.1 Loosen rail screws.

NOTE: If bottom rail contains locking mechanism, ensure rail is in proper orientation for lock usage.

5.2.2 Slide rails onto top and bottom of glass panel.

NOTE: Place shim blocks in bottom rail.

5.2.3 Fully tighten and torque rail screws.

NOTE: Onto scrap material, first dispense approximately 12" of 3M™ Scotch-Weld™ Urethane Adhesive prior to application to prevent mixing errors and ensure optimal hardening.

5.2.4 Dispense into filling holes in rails. **⚠** Stop application when adhesive can be seen past edge of rail.

⚠ DO NOT WIPE any excess adhesive from glass surface. Allow adhesive to dry and scrape off glass surface with a beveled-edge chisel or putty knife.

5.3 Installing three piece lock

Fig 27

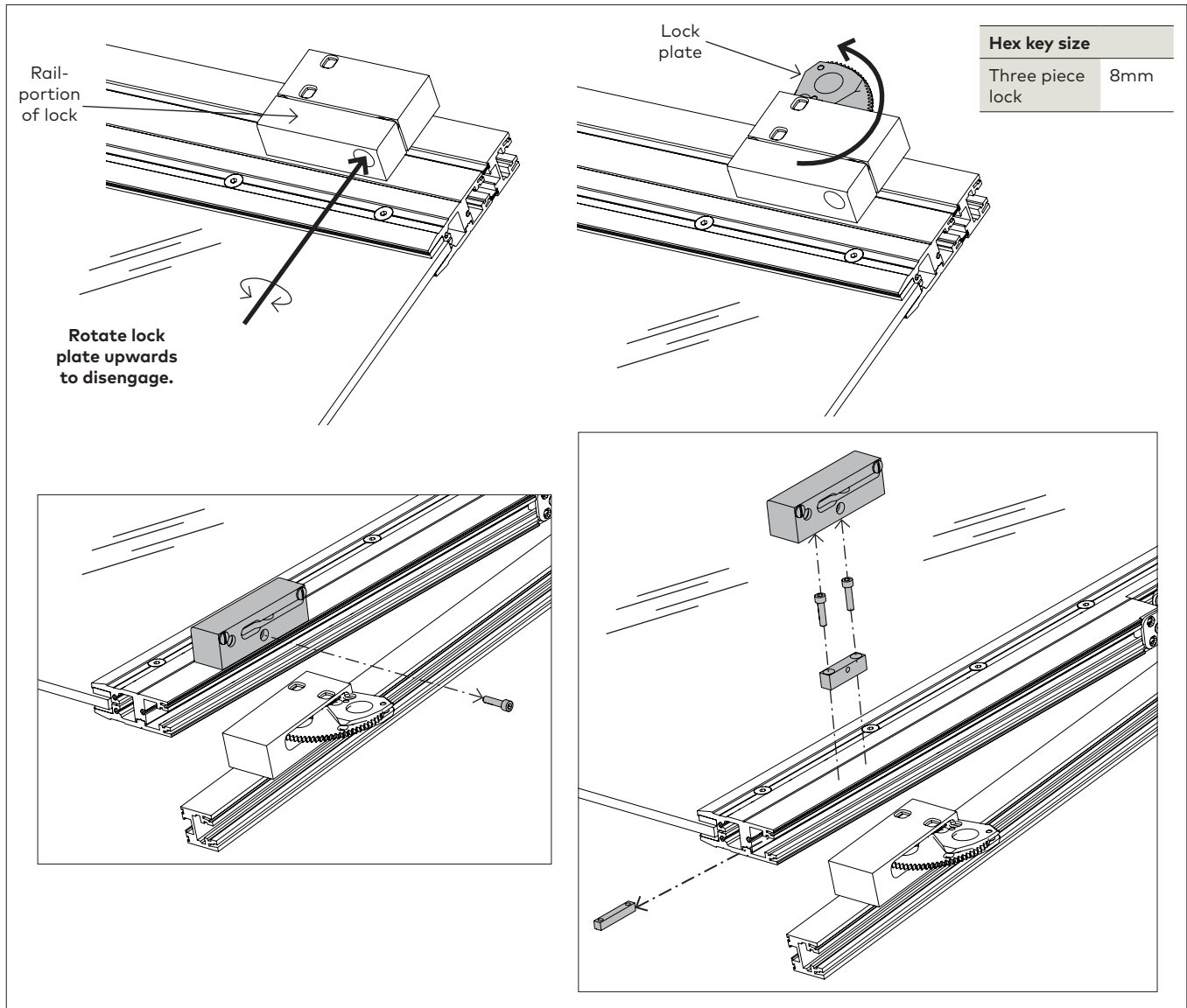

5.3.1 Rotate lock plate up to disengage from the rail, via screw in rail-portion of the lock.

5.3.2 Remove lock parts on rail and set aside for later reinstall.

5.4 Prep for installing two piece lock (when required)

Fig 28

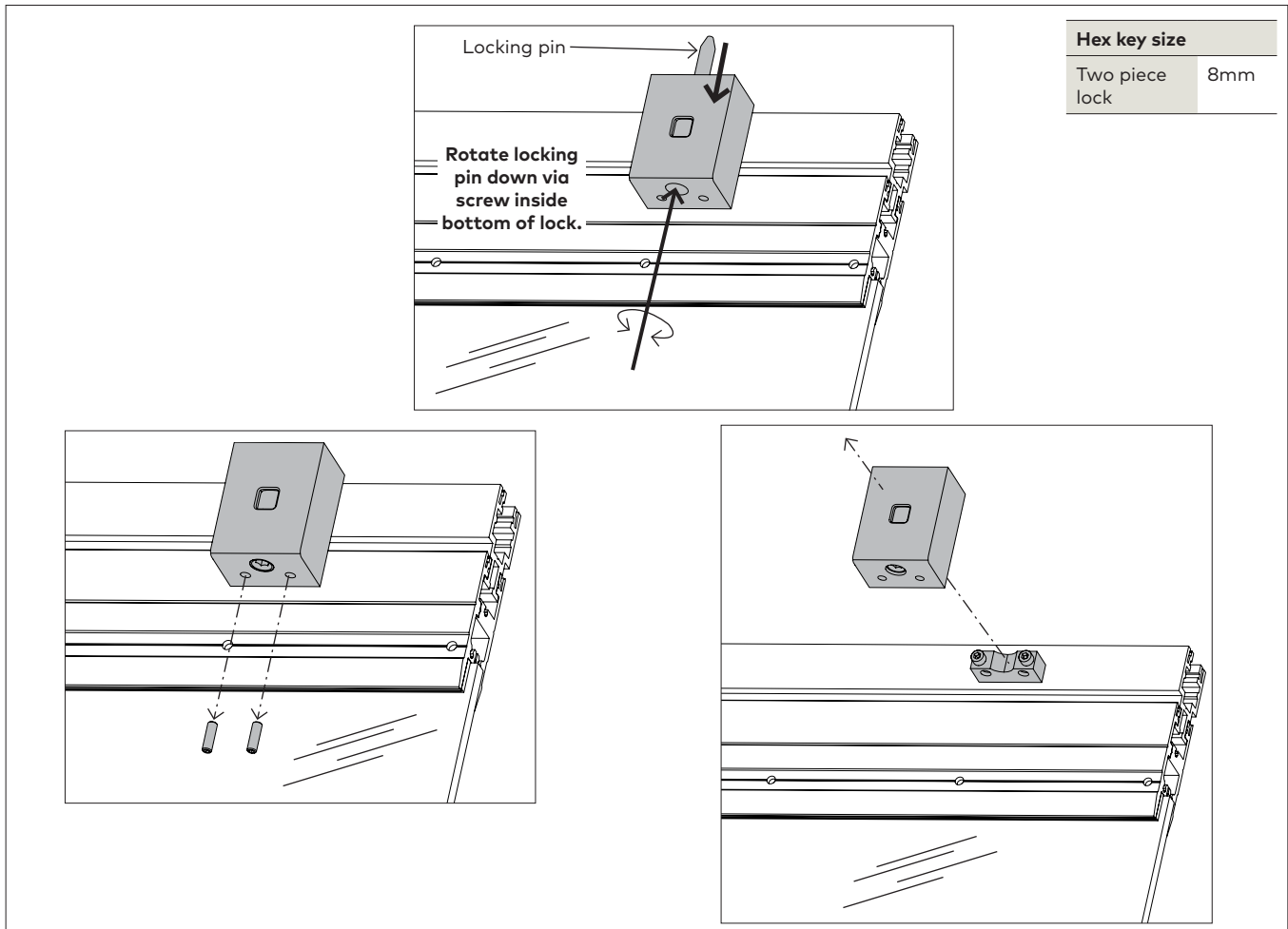

5.4.1 Rotate locking pin down via screw inside bottom of the lock.

5.4.2 Remove lock parts and set aside for later reinstall.

5.5 Install top cover and carrier profile gaskets

Fig 29

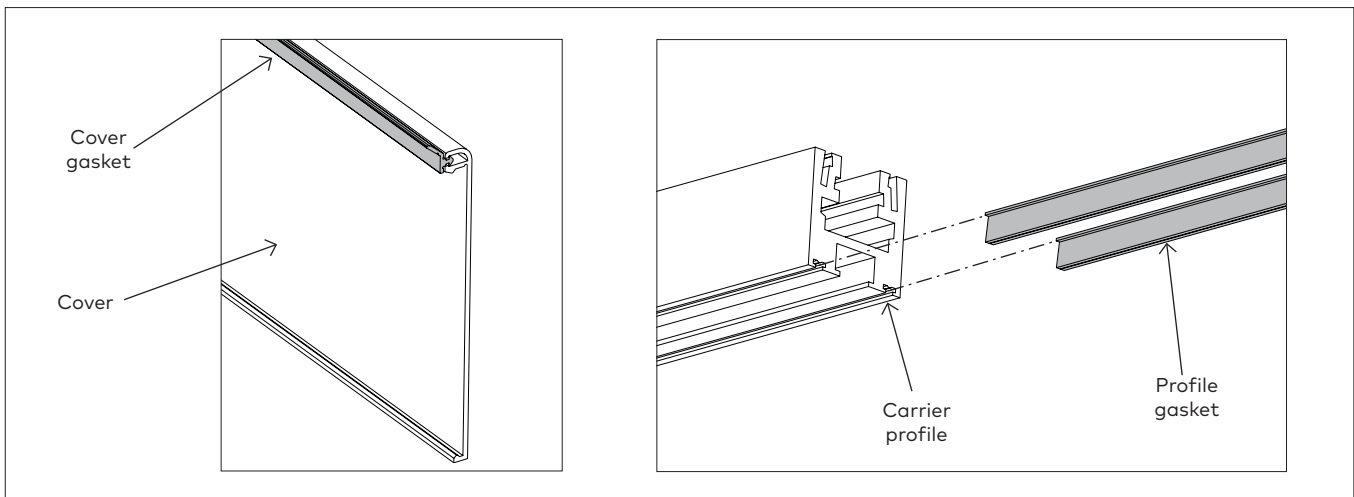

5.5.1 Press cover gasket into top cover.

5.5.2 Slide profile gasket into carrier profile.

5.6 Installing three piece lock (continued)

Fig 30

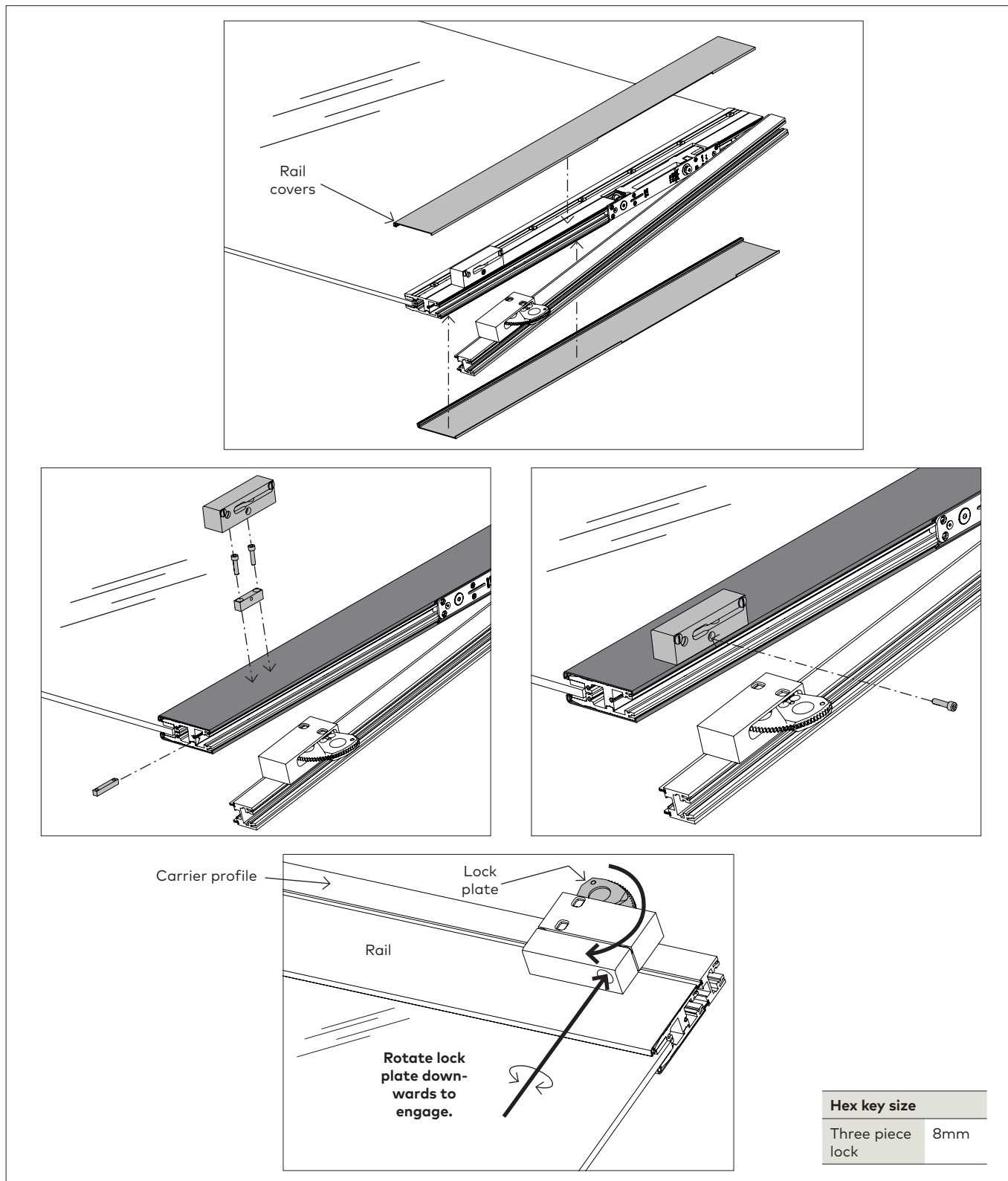

5.6.1 Secure rail covers.

5.6.2 Reinstall lock parts over covers.

5.6.3 Rotate lock plate down to lock carrier profile and rail together.

- Use screw in rail-portion of the lock.

5.7 Install two piece lock (continued)

Fig 31

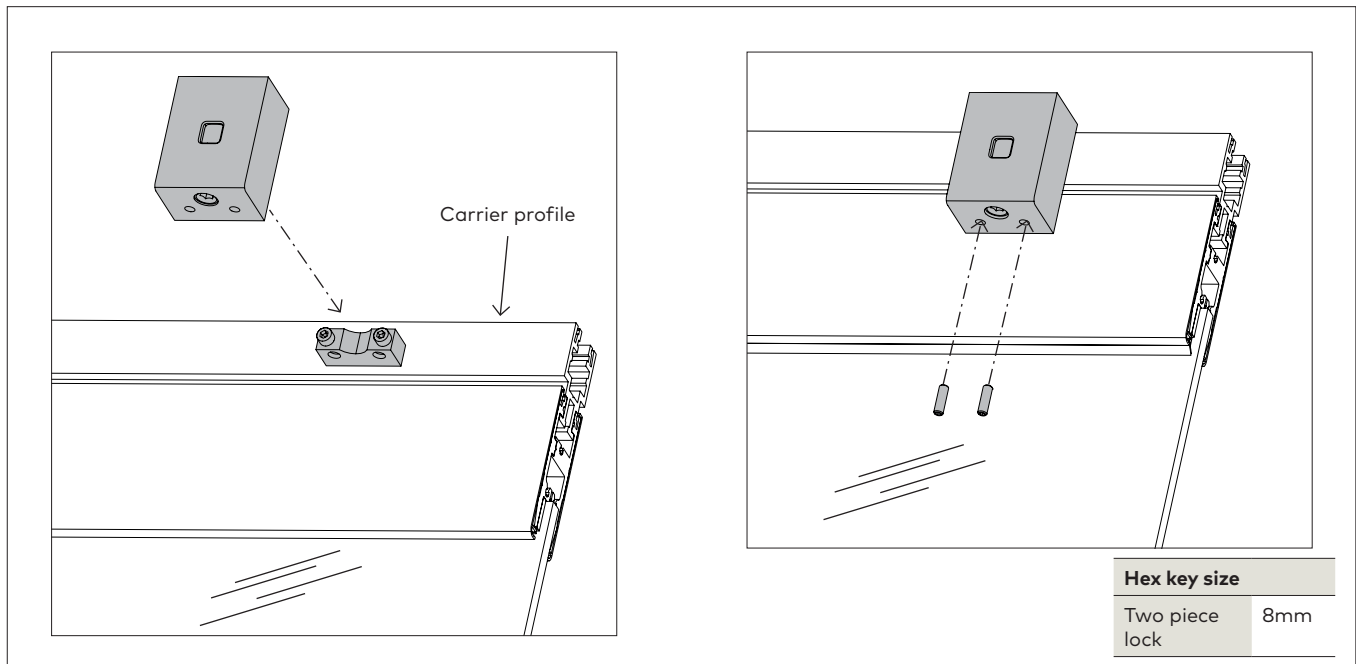

5.7.1 Reinstall lock parts over covers onto carrier profile.

5.8 Installing DA sliding panels onto rollers and adjust door height

Fig 32

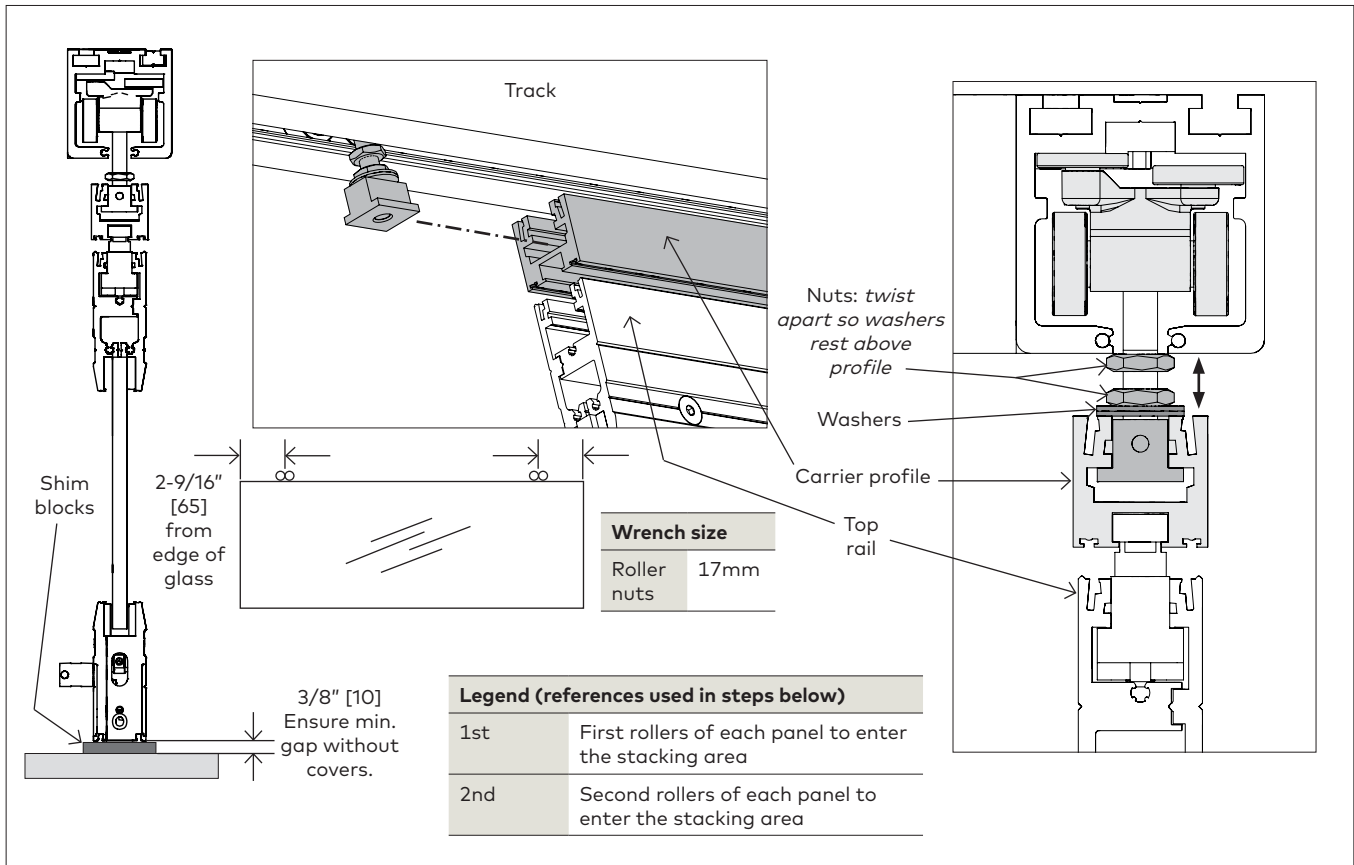

- 5.8.1 Rest glass panel on 3/8" [10] shim blocks.
 - 5.8.2 Ensure one roller is on each side of panel.
 - 5.8.3 Insert rollers into carrier profile:
 - **REFER TO STEP 2.8 FOR ROLLER PATTERN.**
 - Twist nuts apart such that **washers** will rest **above** carrier profile.
 - **Sliding panels:** slide one roller into each end of the carrier profile. (a "2nd" and a "1st" for each)
- NOTE: For perpendicular stacking: center of "2nd" roller must be 2-9/16" [65] from edge of glass.**

- NOTE: For parallel stacking: rollers are adjustable.**
- 5.8.4 Slide panels into stacking area, and allow "1st" roller to naturally settle into place within the carrier profile.
 - 5.8.5 Then, slide all panels out into the straight run again for horizontal adjustment.
 - 5.8.6 **Adjust door height:**
 - Loosen lower nut.
 - Rotate upper nut to raise or lower door.
 - **Ensure a minimum 3/8" [10] gap between bottom of door and floor (without covers).**
 - 5.8.7 DO **NOT** FULLY TIGHTEN NUTS AT THIS POINT.

5.9 Secure three piece lock to track

Fig 33

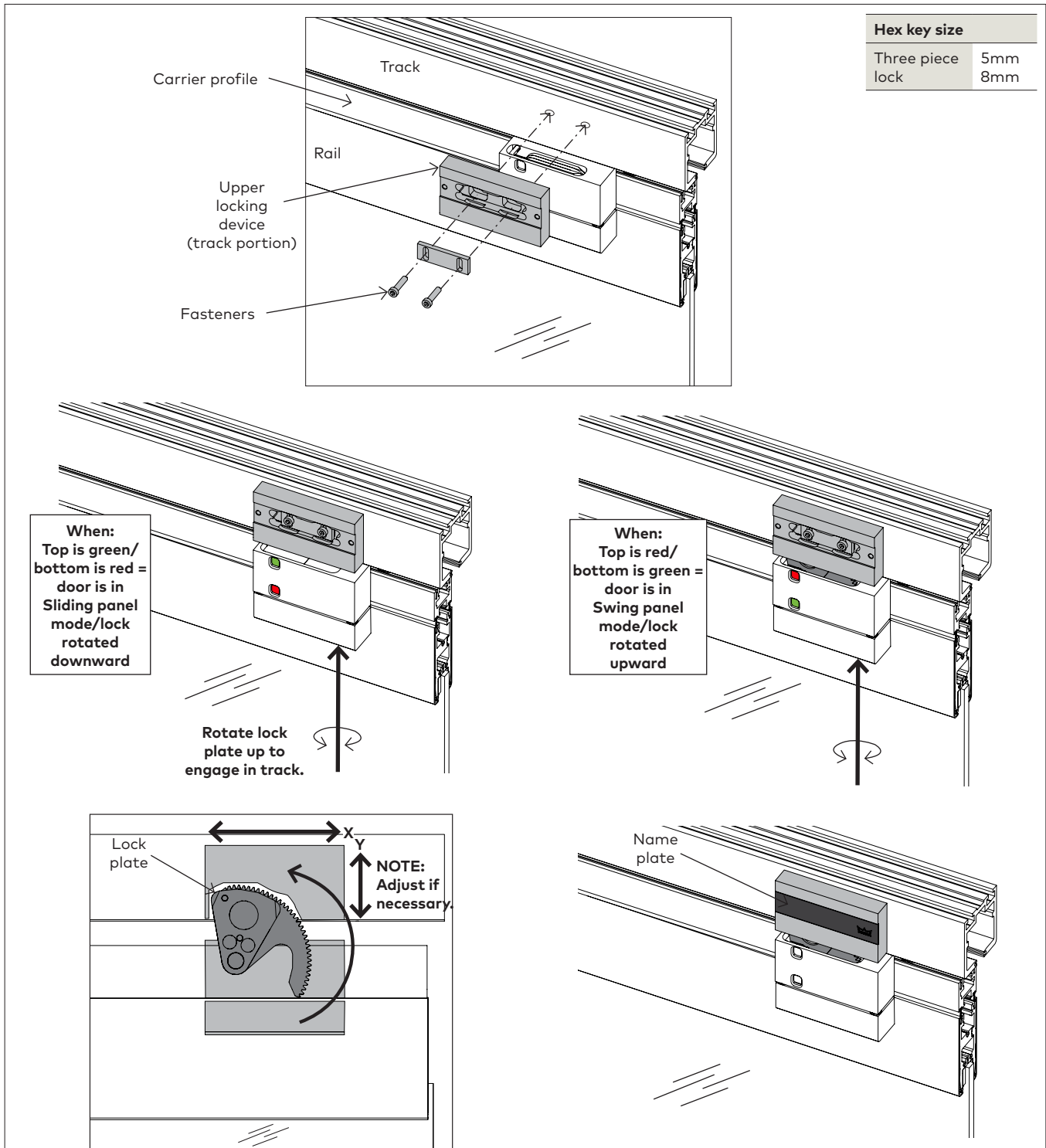

- 5.9.1 Secure upper locking device parts to track.
 - Hand tighten only.
- 5.9.2 Rotate locking plate up to engage in track portion of lock.
 - Use screw via lower section of locking device.
- 5.9.3 Adjust track portion of locking device horizontally [x] and vertically [y] to ensure proper engagement.

- Fully tighten fasteners.
- 5.9.4 Place dormakaba name plate over front of lock.
- 5.9.5 **To put in sliding panel mode:** rotate locking plate up to engage in track portion of lock.
To put in swing panel mode: rotate locking plate down to disengage from track portion of lock.

5.10 Secure two piece lock to track

Fig 34

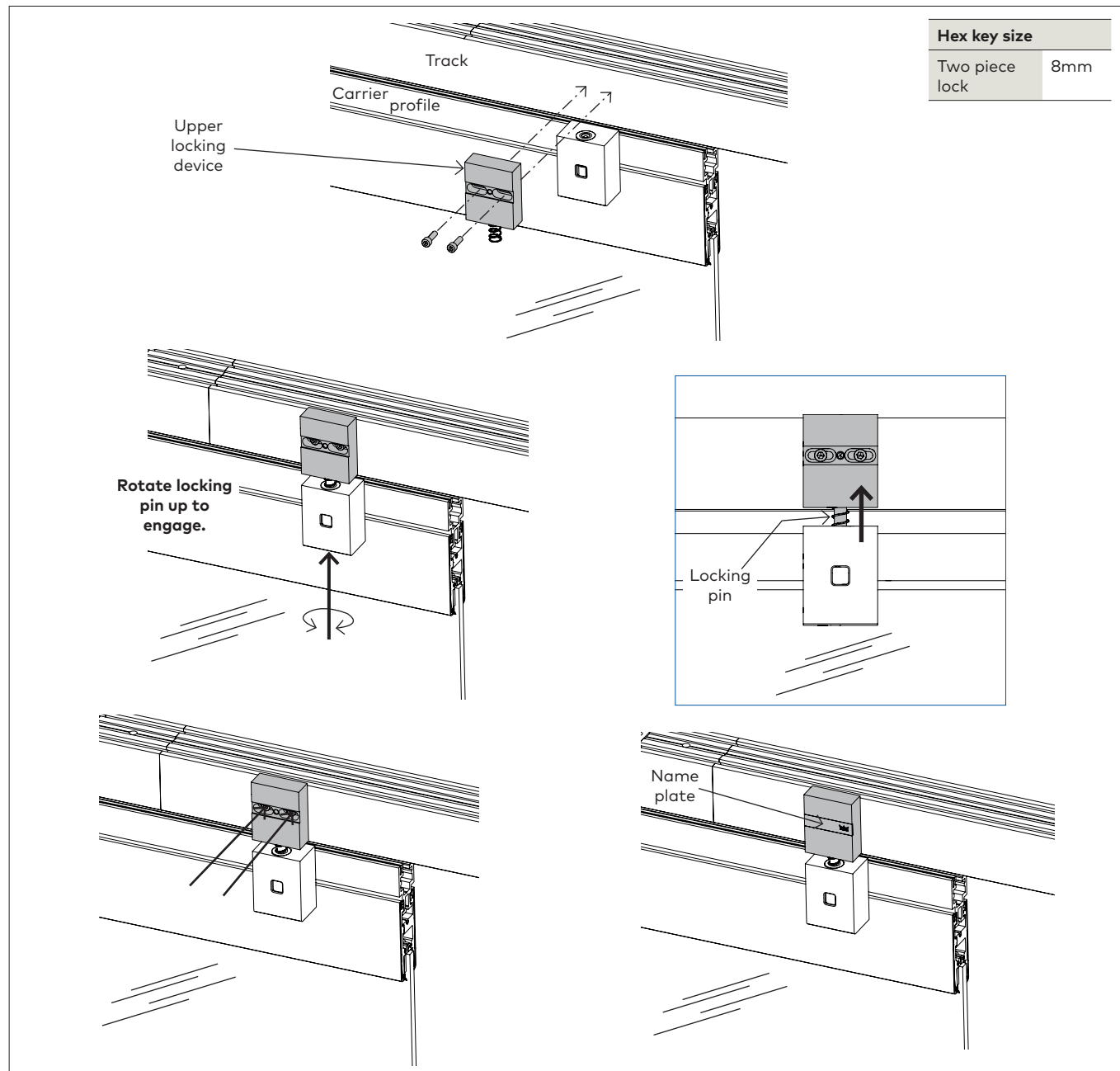

- 5.10.1 Secure upper locking device parts to track.
- Hand tighten only.
- 5.10.2 Rotate locking pin up to engage.
- Use screw via lower section of locking device.
- 5.10.3 Adjust track portion of locking device horizontally and vertically to ensure proper engagement of pin.
- Fully tighten fasteners.

- 5.10.4 Place dormakaba name plate over front of lock.
- 5.10.5 **To open door/unlock:** rotate locking pin up to engage.
- To lock:** rotate locking pin down to disengage.

5.11 ITS96 closer adjustment

Fig 35

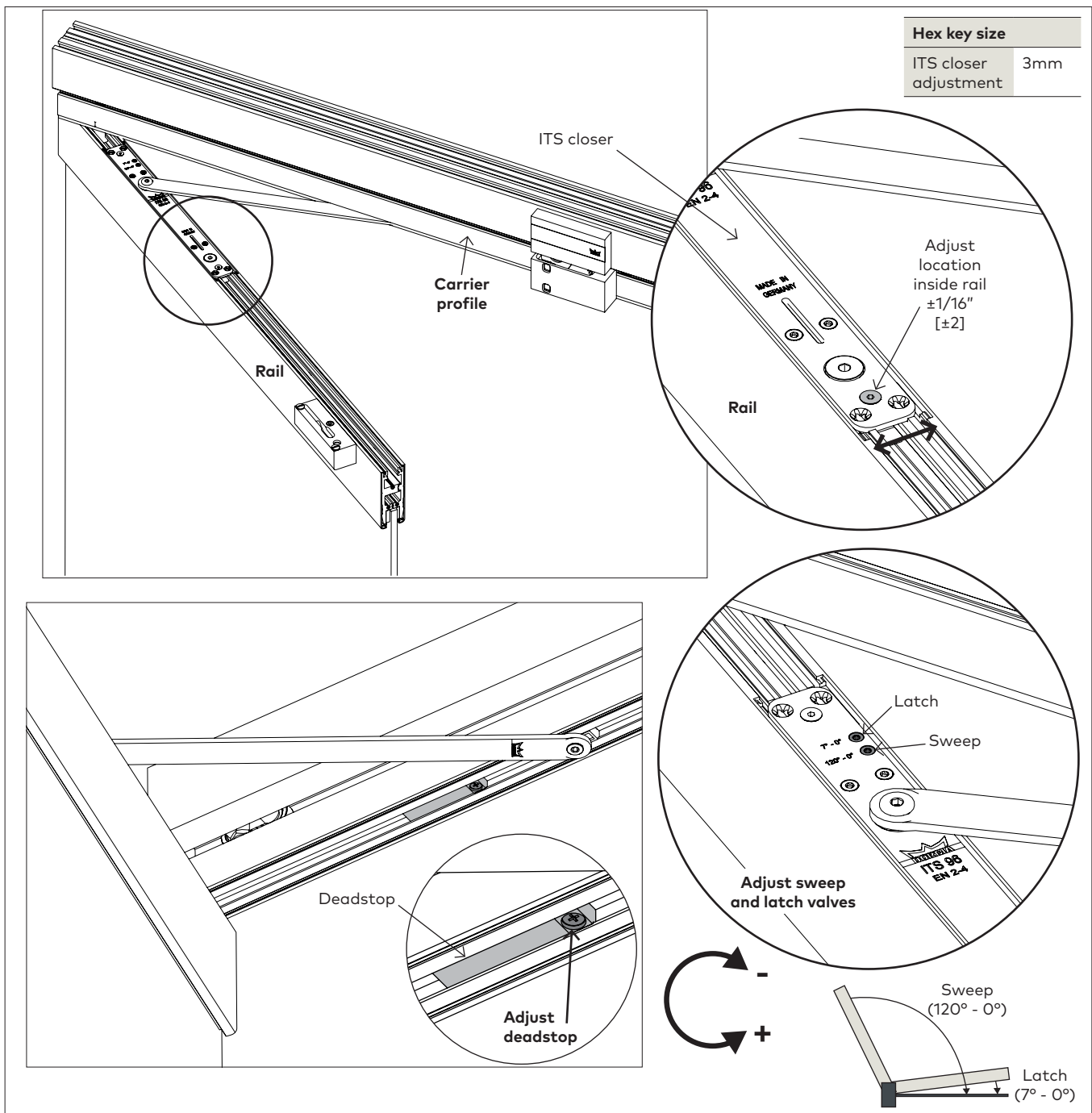

5.11.1 Adjust the ITS closer location inside the rail.

NOTE: Ensure it is centered inside the rail.

NOTE: Closer is already pre-loaded at 45°. Not further pre-loading steps are needed.

Adjust deadstop:

5.11.2 Open door to desired opening between 80° and 120°.

5.11.3 Slide deadstop cushion into place.

5.11.4 Tighten deadstop screw.

Adjust sweep and latch:

5.11.5 Adjust via set screws in top of closer.

- Sweep: increase or decrease
- Latch: increase only

5.12 ITS96 hold open (optional) and spring force adjustment

Fig 36

Hold open mechanism
Secure in place

Adjust
(clockwise/counterclockwise)

Enable
Disable

Arm slide

Hex key size	
ITS96 hold open mechanism	2.5mm

BARRIER-FREE OPENINGS - Adjust only if more tension is required to close and latch the door. Depending on opening conditions, a door adjusted to meet barrier-free forces may not have sufficient power to reliably close and latch the door.

NON-BARRIER-FREE OPENINGS - Adjust according to chart.

Door width (Interior)	Maximum door weight (lbs)	Full turns of spring adjuster (ITS9613)	Full turns of spring adjuster (ITS9625)	Spring size
2'-6"	100	8	N/A	2
3'-0"	125	15	-5	3
3'-6"	150	N/A	0	4
4'-0"	175	N/A	8	5

Spring tension

90 EN 24
MADE IN GERMANY

- 5.12.1 Open door and place hold open mechanism in desired position.
- 5.12.2 Secure mechanism in place.
- 5.12.3 **Adjust hold open:**
 - **Increase force** = turn clockwise
 - **Decrease force** = turn counter clockwise
- 5.12.4 **To enable hold open:** open door and push arm slide onto hold open mechanism.
- 5.12.5 **To disable hold open:** close door and pull arm slide off of hold open mechanism.

- 5.12.6 **Adjust spring force:**
 - Increase spring force = turn clockwise
 - Decrease spring force = turn counter clockwise

6 Installation instructions - Fixed panel door

6.1 Preparing the fixed panel door (with monolithic glass only)

Fig 37

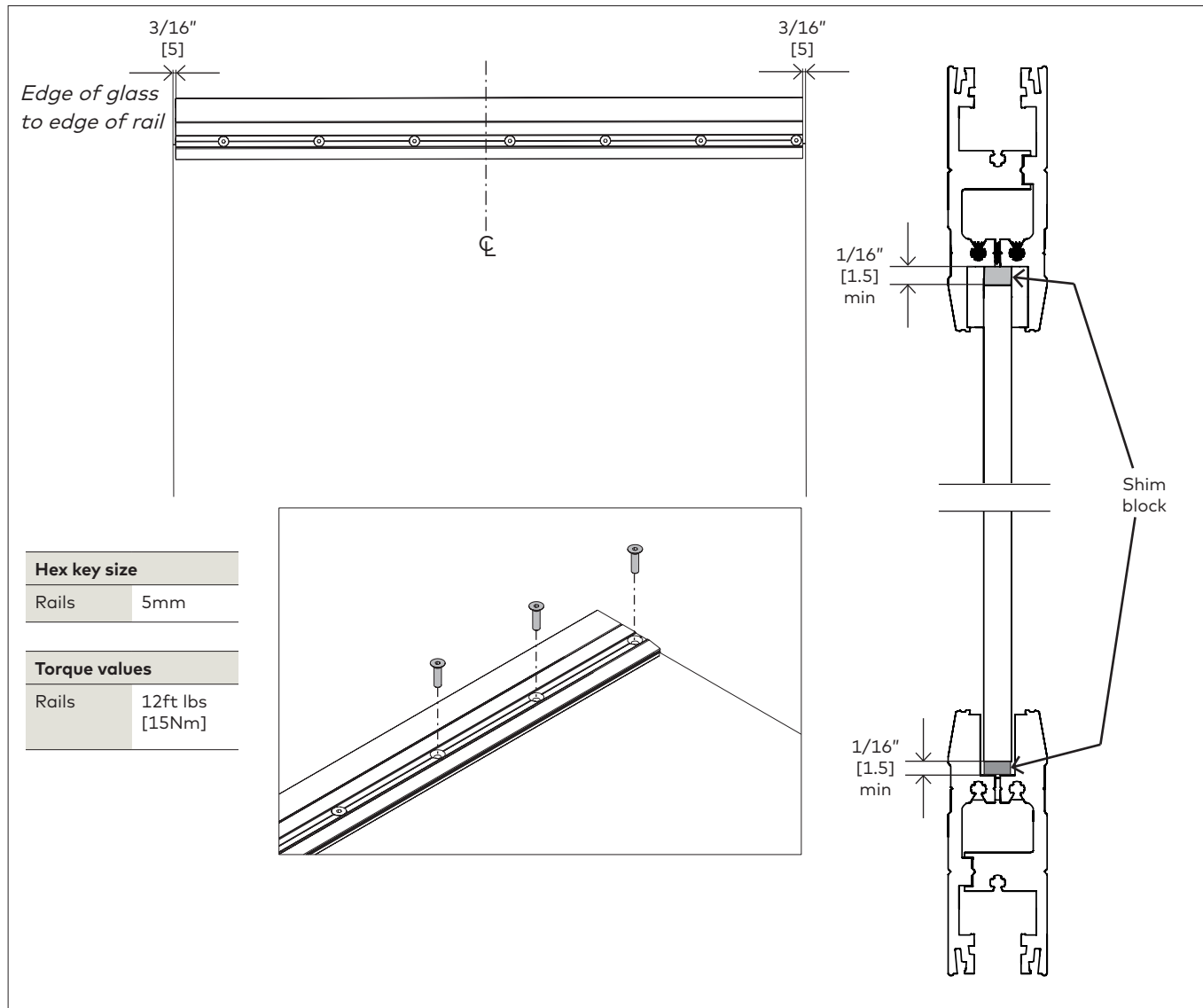

- ⚠ NOTE: FULLY CLEAN SURFACE OF GLASS WITH AN ALCOHOL-BASED MILD GLASS AND SURFACE CLEANER.**
- ⚠ ENSURE RAIL GASKET IS FREE OF DEBRIS.**
- ⚠ NOTE: ENSURE RAILS ARE SQUARE PRIOR TO HANGING DOOR TO AVOID EXCESSIVE DOOR ADJUSTMENT ONCE PANEL IS INSTALLED. MEASURE FOR CORRECT PANEL HEIGHT.**

6.1.1 Lay glass panel on a flat surface.

6.1.1 Loosen rail screws.

NOTE: If bottom rail contains locking mechanism, ensure rail is in proper orientation for lock usage.

6.1.2 Slide rails onto top and bottom of fixed glass panel.

NOTE: Place shim blocks in bottom rail.

6.1.3 Fully tighten and torque rail screws.

6.2 Preparing the fixed panel door (with tempered laminated glass only)

Fig 38

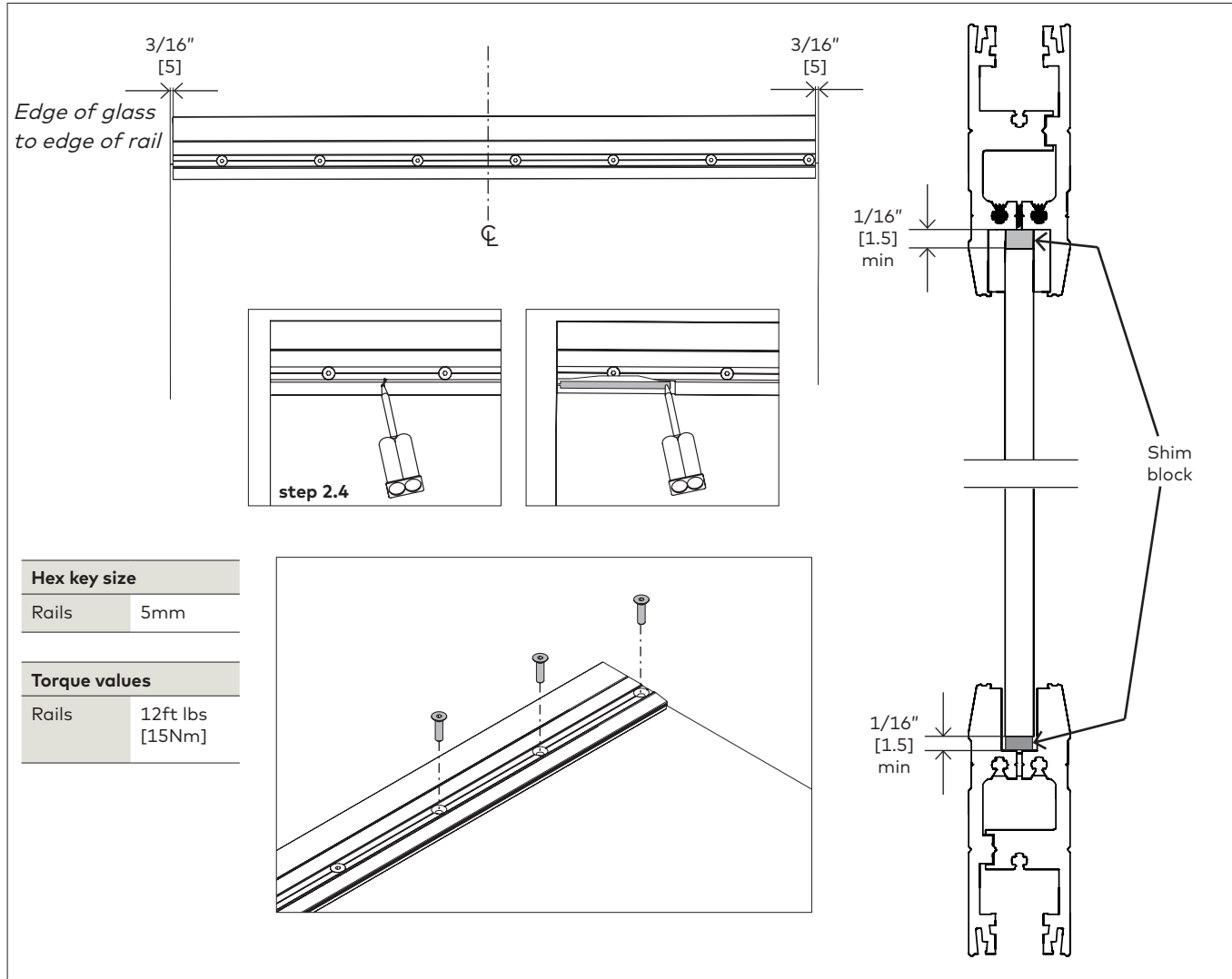

- ⚠ NOTE: THE RECOMMENDED ADHESIVE'S SET-UP TIME IS 20 MINUTES FOR THE DUO-PAK CARTRIDGES.**
- ⚠ NOTE: USE 1:1 RATIO PLUNGER WITH THE 3M™ Scotch-Weld™ Urethane Adhesive.**
- ⚠ NOTE: FULLY CLEAN SURFACE OF GLASS WITH AN ALCOHOL-BASED MILD GLASS AND SURFACE CLEANER. ENSURE NO DEBRIS IS ON THE GASKET.**
- ⚠ NOTE: ENSURE RAILS ARE SQUARE PRIOR TO SECURING WITH ADHESIVE TO AVOID EXCESSIVE DOOR ADJUSTMENT ONCE PANEL IS INSTALLED. MEASURE FOR CORRECT PANEL HEIGHT.**

6.2.1 Lay glass panel on a flat surface.

6.2.1 Loosen rail screws.

NOTE: If bottom rail contains locking mechanism, ensure rail is in proper orientation for lock usage.

6.2.2 Slide rails onto top and bottom of fixed glass panel.

NOTE: Place shim blocks in bottom rail.

6.2.3 Fully tighten and torque rail screws.

NOTE: Onto scrap material, first dispense approximately 12" of 3M™ Scotch-Weld™ Urethane Adhesive prior to application to prevent mixing errors and ensure optimal hardening.

6.2.4 Dispense into filling holes in rails.

⚠ Stop application when adhesive can be seen past edge of rail.

⚠ DO NOT WIPE any excess adhesive from glass surface. Allow adhesive to dry and scrape off glass surface with a beveled-edge chisel or putty knife.

6.3 Installing the fixed panel holders

Fig 39

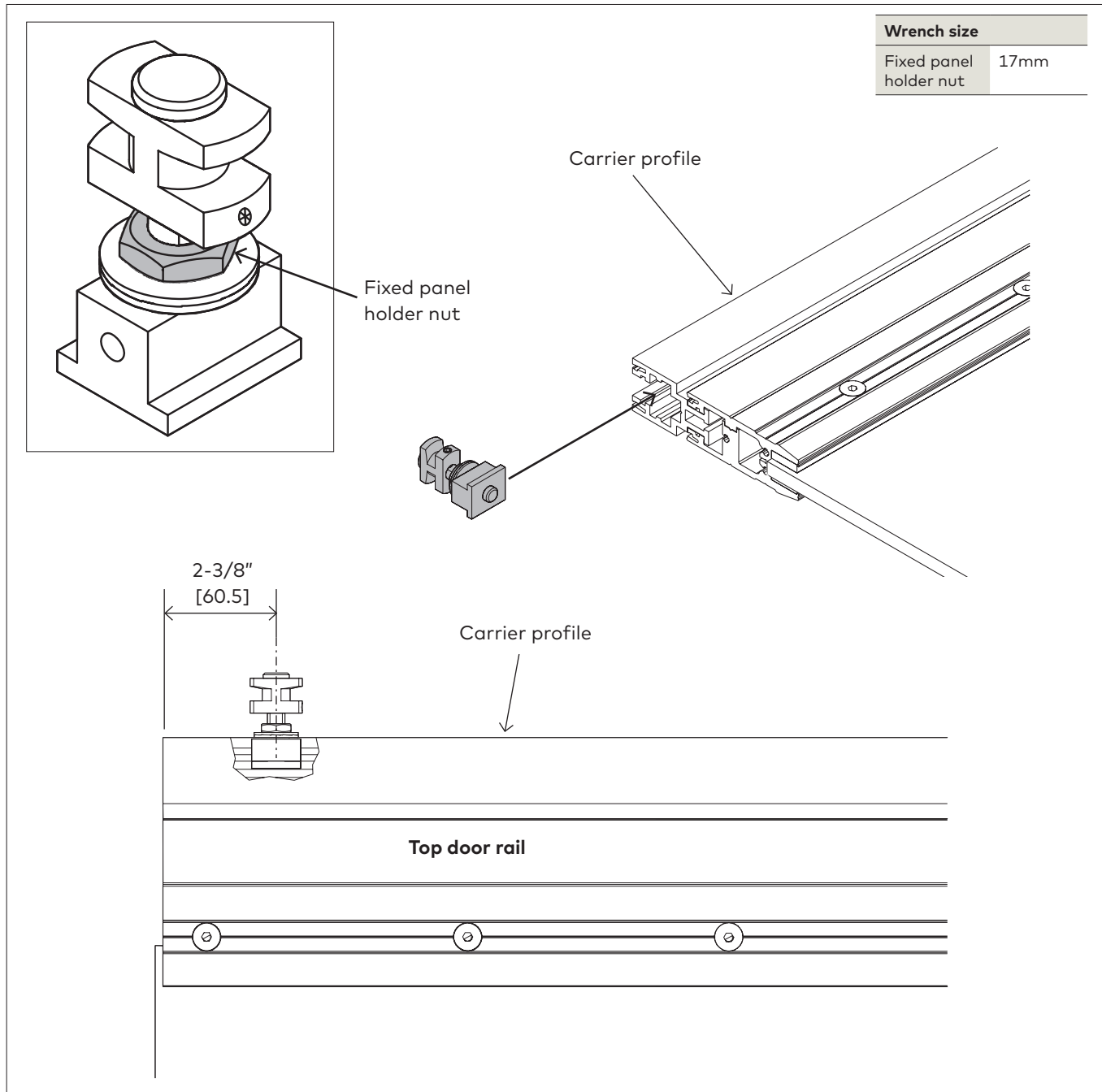

6.3.1 Loosen fixed panel holder nut.

6.3.2 Slide holders into each end of the carrier profile at the top of the door.

6.3.3 Ensure fixed panel holder is 2-3/8" [60.5] from edge of rail and nut sits above the profile.

6.3.4 Hand tighten nuts.

6.4 Installing the saddle and fixed panel door

Fig 40

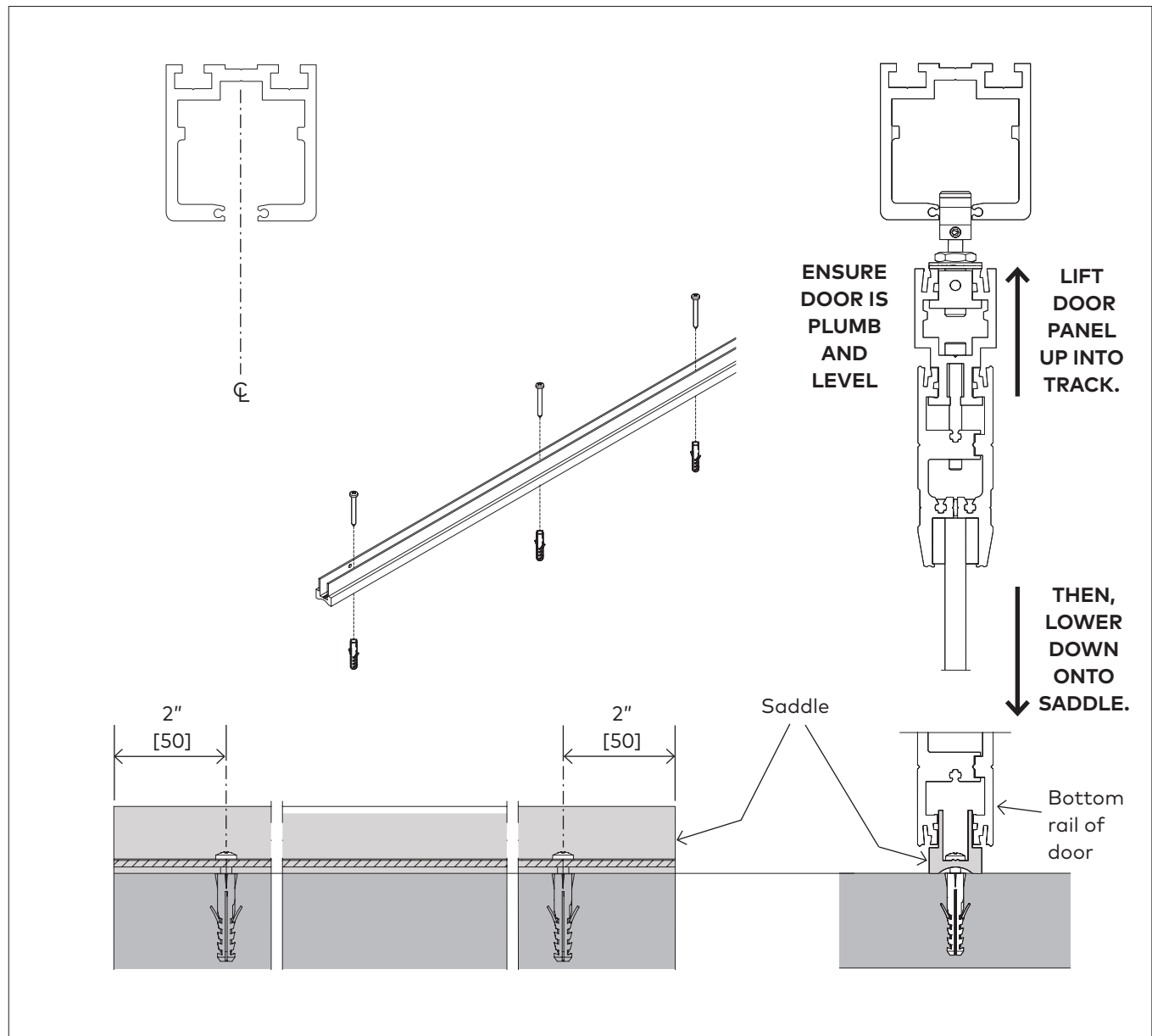

- 6.4.1 Locate centerline of track using laser or plumbob.
- 6.4.2 Align saddle with centerline of track.
- 6.4.3 Mark and pre-drill holes in the floor surface.

- 6.4.4 Secure saddle to floor using fasteners appropriate to the floor surface material.
- 6.4.5 Lift door panel up into track.
- 6.4.6 Lower door panel down onto saddle.

6.5 Adjusting and securing fixed panel door

Fig 41

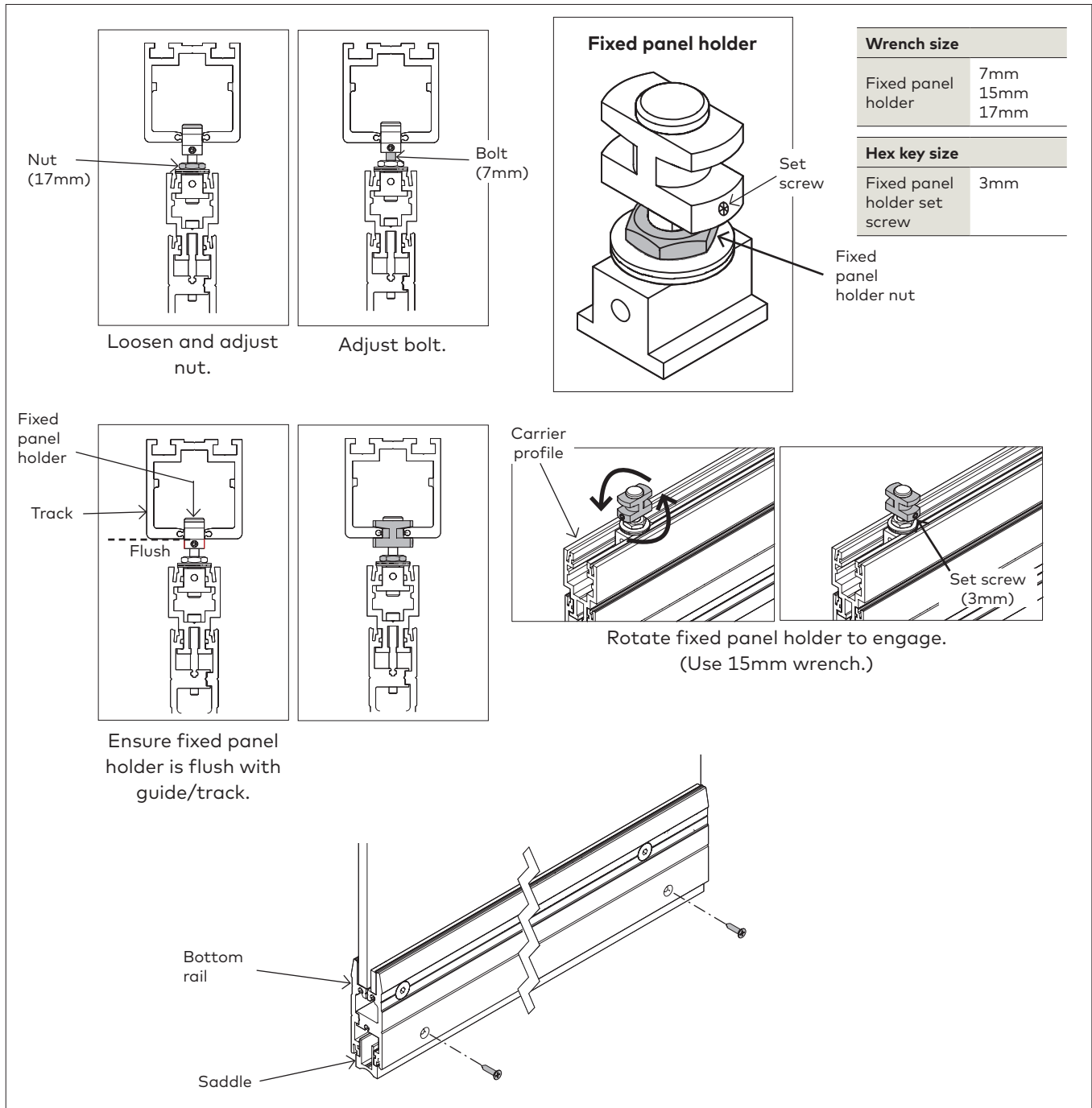

- 6.5.1 Loosen fixed panel holder nut.
- 6.5.2 Adjust nut and bolt until fixed panel holder is flush with track.
- 6.5.3 Rotate fixed panel holder 90° inside track to engage.

- 6.5.4 Secure fixed panel holder via set screw.
- 6.5.5 Secure door height with nut.
- 6.5.6 Secure fixed panel door and bottom rail to saddle with proper fasteners.

6.6 Install gasket and top cover

Fig 42

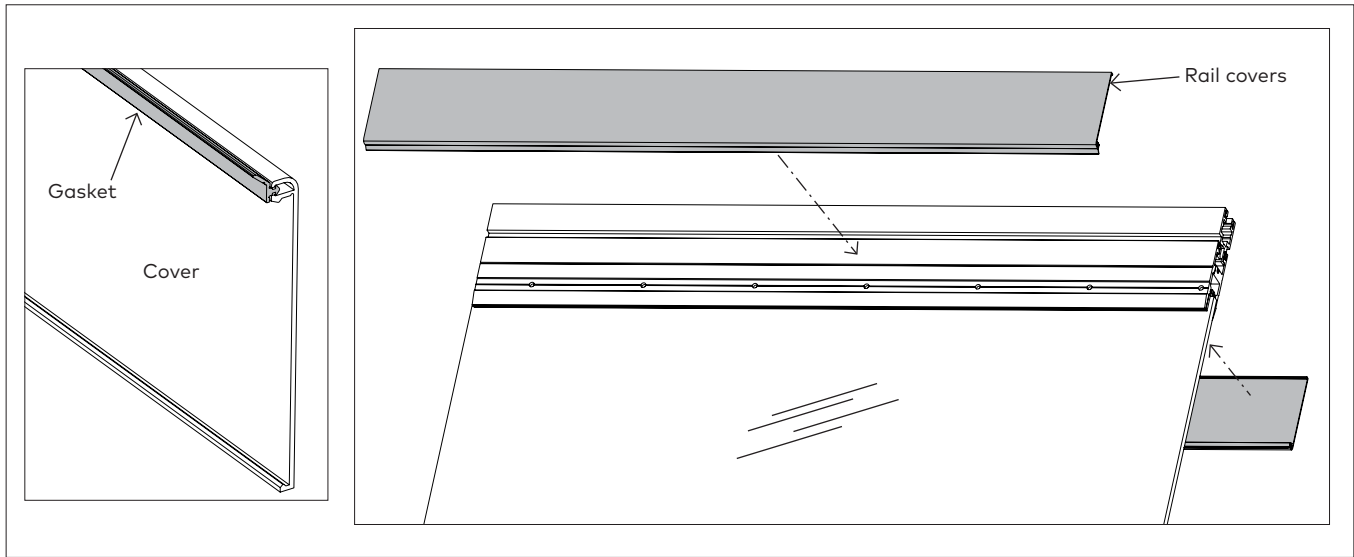

6.6.1 Push gasket into top cover.

6.6.2 Snap covers onto rails.

7 Installation instructions - Alignment, covers, end caps, miscellaneous

7.1 Aligning panels into stacking area

Fig 43

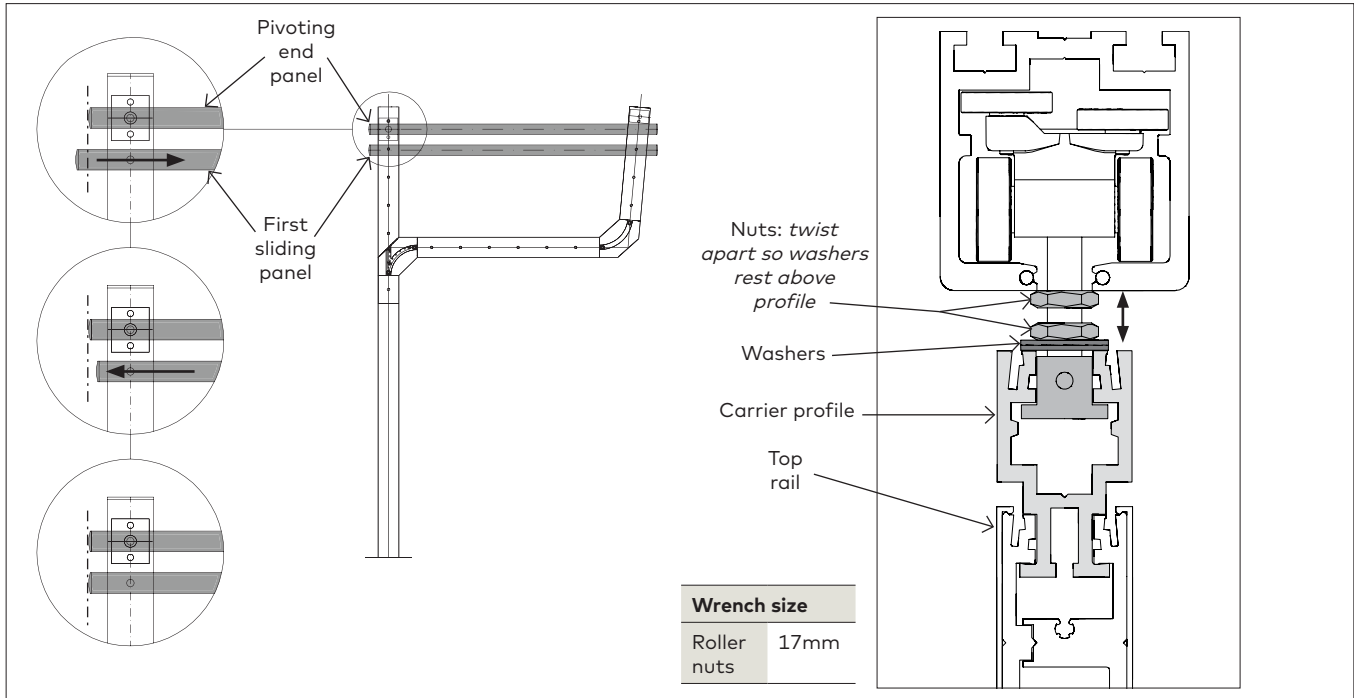

7.1.1 Slide panels **back** into stacking area accordingly.

7.1.2 With upper nuts loose, slide panel left or right to align each sliding panel with the pivoting end panel. (See image above.)

7.1.3 **Fully** tighten in place with lower nut.

7.2 Aligning panels side by side in straight run

Fig 44

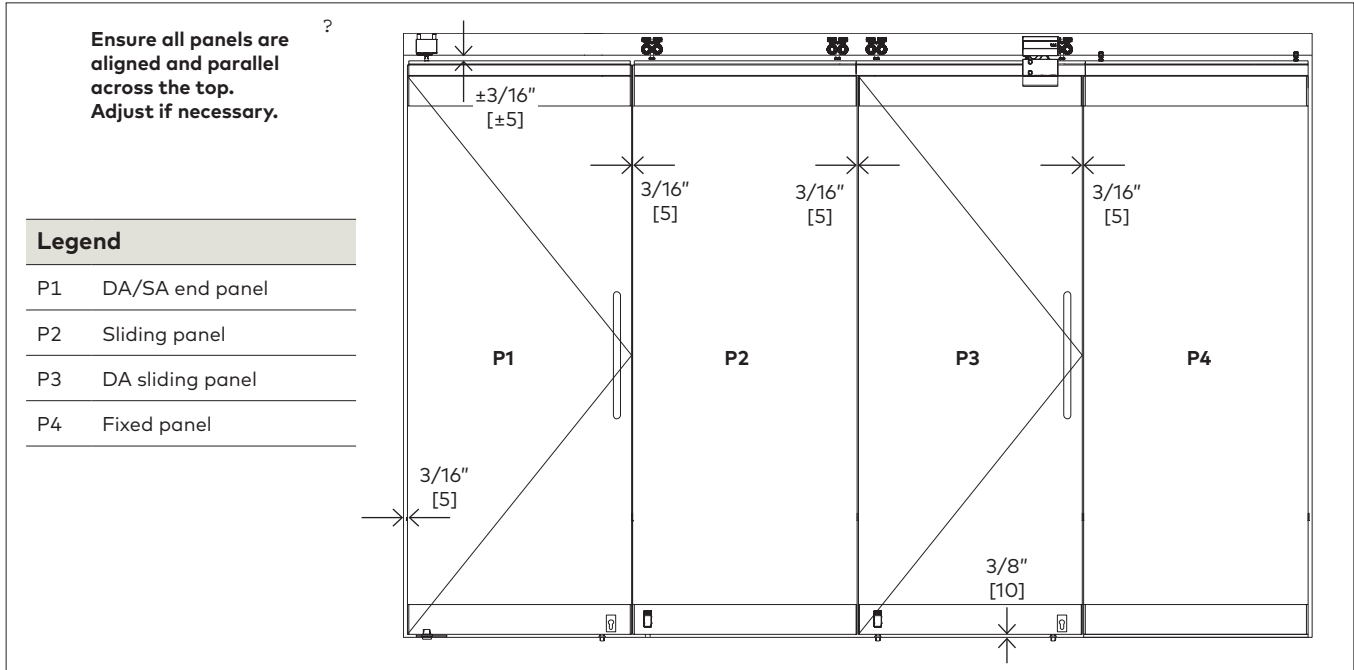

7.2.1 Slide panels into place along straight run of track.

NOTE: Ensure a 3/16" [5] gap between each panel.

NOTE: End cap bumpers should touch when proper gap is achieved. (See step 7.8 for end cap bumpers location.)

NOTE: Ensure all panels are level across the top. Adjust if necessary.

NOTE: Use nut on roller to adjust height and, plumb and align panels. (See step 7.1 for roller nut location).

NOTE: Europe systems will show swing panel opposite of US version.

7.3 Secure carrier profile file connecting inserts and end caps

Fig 45

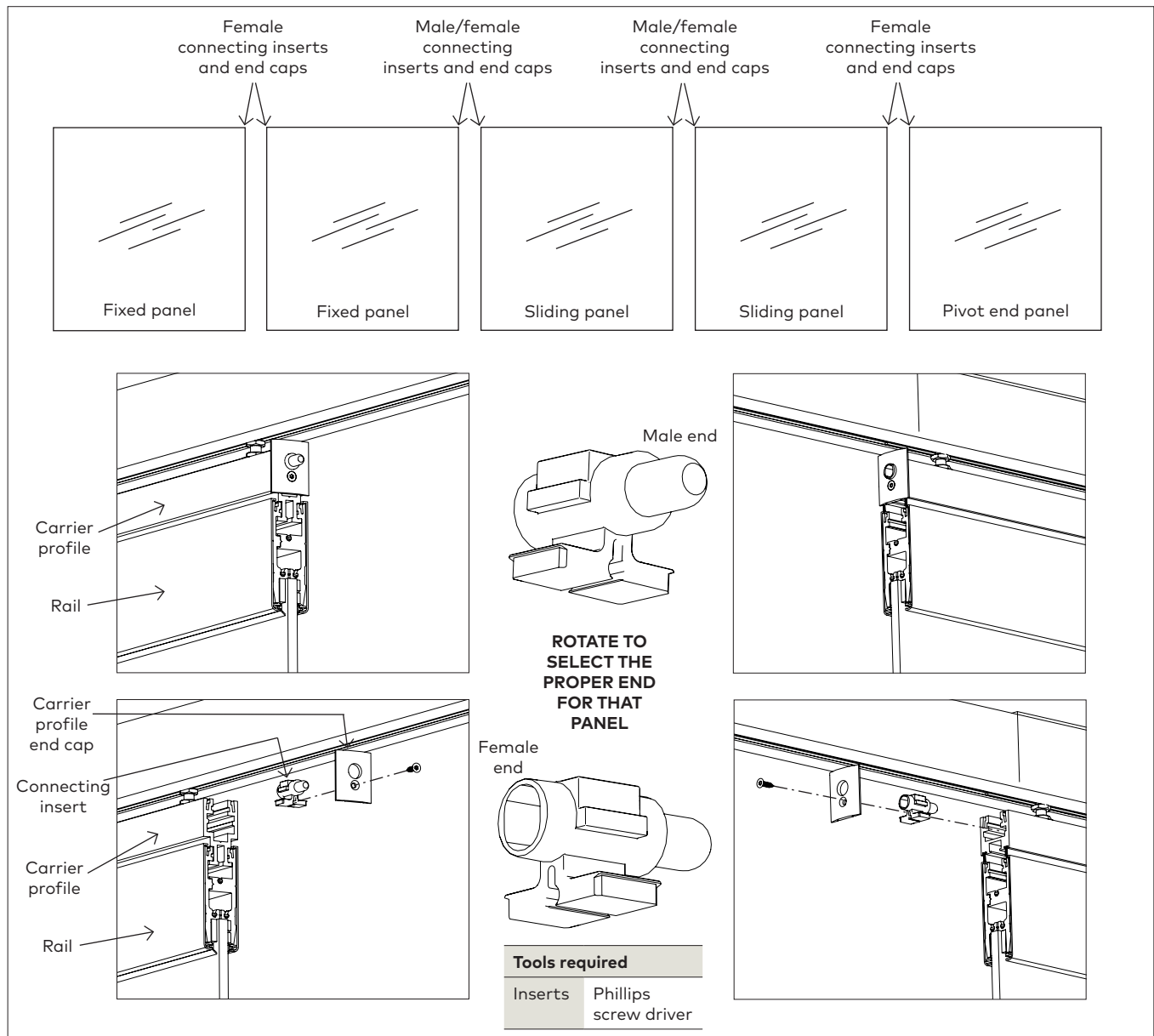

7.3.1 **Sliding panel:** slide coordinating male/female connecting inserts and end caps into open ends of carrier profiles.

7.3.2 **Fixed panels:** select proper end cap dependent upon the type of panel adjacent to it.

- **Fixed panel/Fixed panel:** each use female connecting insert and end cap
- **Fixed panel/Sliding panel:** use coordinating male/female connecting insert and end cap

7.3.3 **Pivoting end panels:** use female connecting insert and end cap into open ends of carrier profile.

7.4 Drilling for ES locking bolt strike

Fig 46

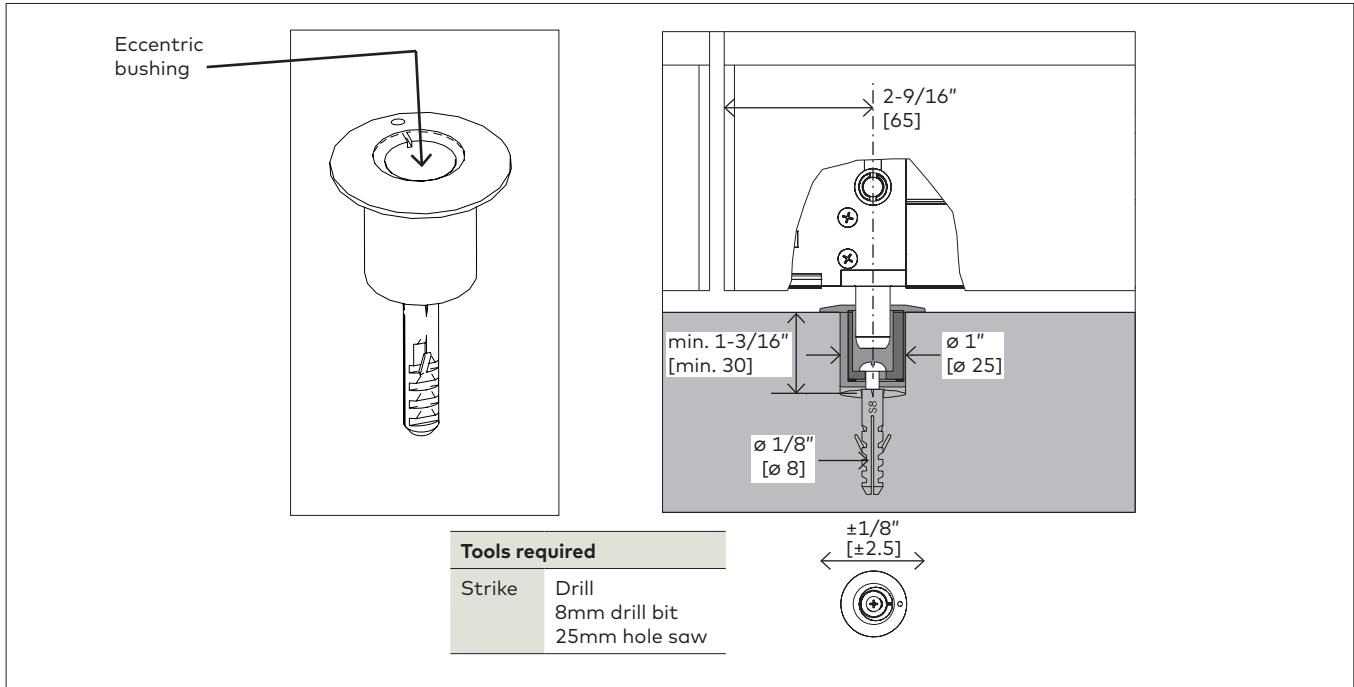

- 7.4.1 With panels in place, lower all strikes down to sit on floor surface.
- 7.4.2 Mark strike location on floor surface.
- 7.4.3 Move panels out of the way.
- 7.4.4 Drill according to specifications in images above.

- 7.4.5 Drop strike into place.
- 7.4.6 Secure with included anchor and fastener.
- 7.4.7 Adjust center of strike location via eccentric bushing inside strike.

7.5 Secure bottom rail covers and rail lock preparation

Fig 47

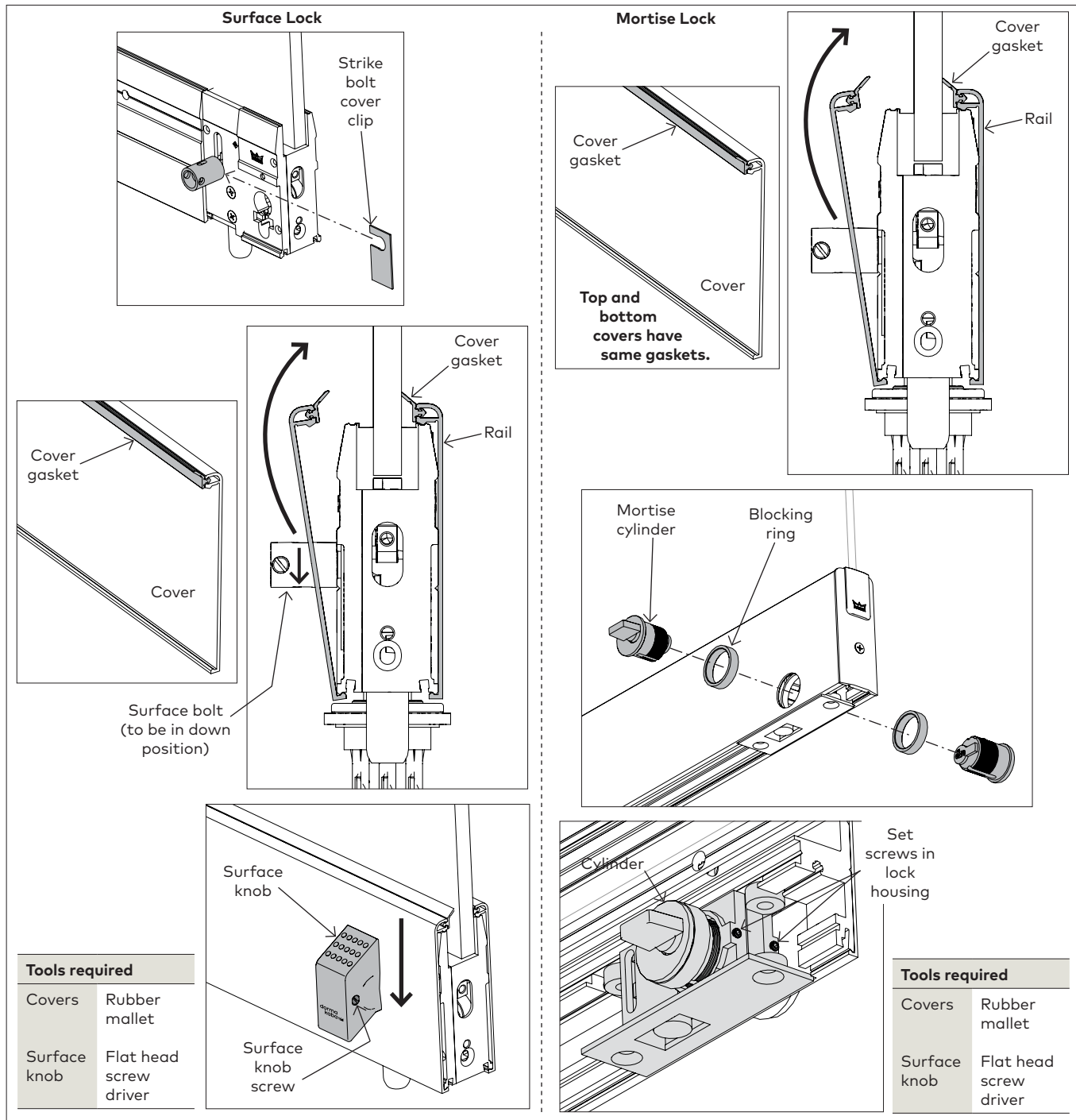

If using surface lock:

- 7.5.1 Slide strike bolt cover clip into place.
- 7.5.2 Push cover gasket into remaining bottom rail covers.
- NOTE: Ensure surface bolt is in down position.**
- 7.5.3 Snap bottom covers into place using a mallet and wood block.
- 7.5.4 **Bottom covers:** slide surface knob onto bolt.
- 7.5.5 Tighten with screw.

If using mortise lock:

- 7.5.1 Push cover gasket into remaining bottom rail covers.
- 7.5.2 Snap bottom covers into place using a mallet and wood block.
- 7.5.3 Install mortise cylinder and blocking ring into rail. **(NOTE: blocking ring included only with 5-pin cylinders.)**
- 7.5.4 Secure cylinder via set screws inside lock housing.

7.6 Installing the brush

Fig 48

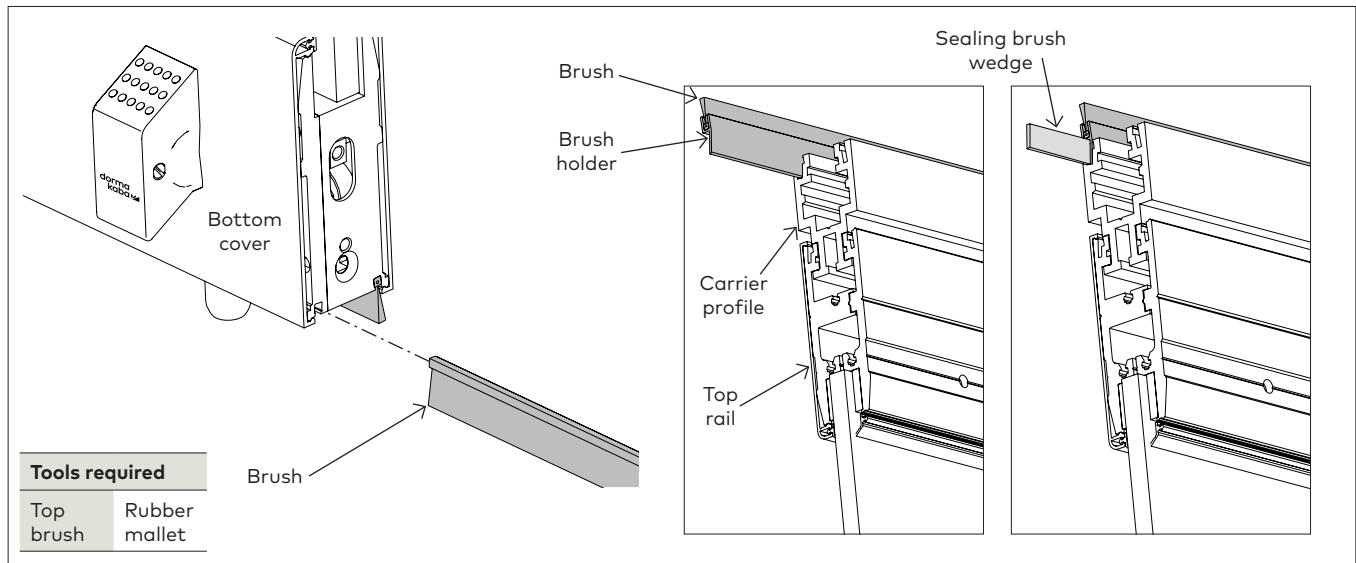

7.6.1 Carrier profile brush:

- slide brush into included brush holder.
- slide brush assembly into carrier profile using the sealing brush wedge. (This will stay in place inside the carrier profile.)

7.6.2 Bottom brush:

- slide brush into bottom cover.

NOTE: Bend slightly to create a small wave in the brush. This will allow it to fit snugly into the groove and not slide out over time.

7.7 Selecting the proper end cap

Fig 49

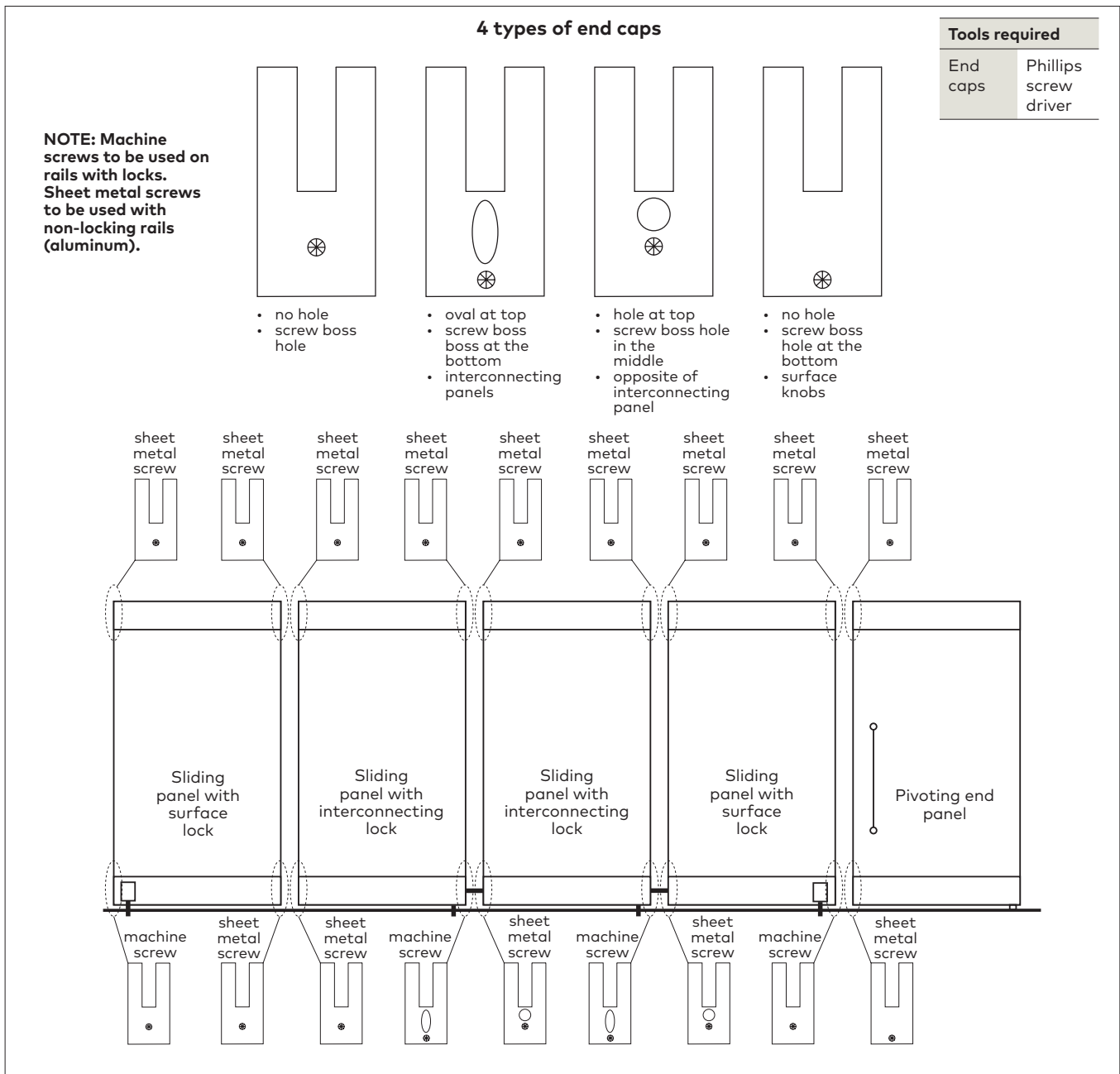

7.7.1 Select the appropriate end cap for the rail.

7.8 Secure the end caps

Fig 50

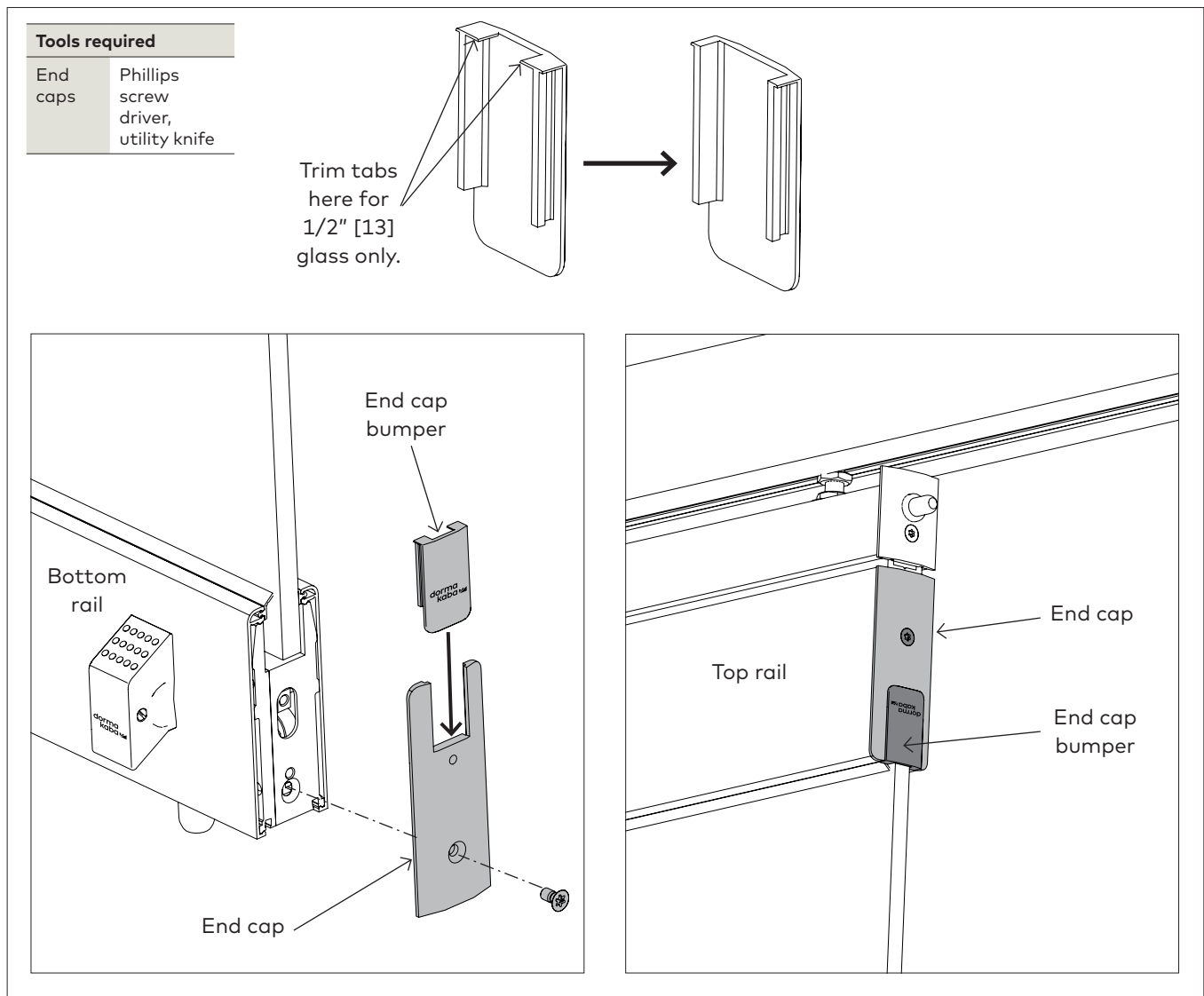

7.8.1 Install end cap.

7.8.2 Slide end cap bumper company into face of each end cap.

NOTE: For 1/2" [13] glass, trim tabs on back of logo cap.

